

35 dB silencers including spark arrestor

The 35 dB type silencers are designed and manufactured to provide high performance over a wide frequency-range and are delivered including an integrated spark arrestor, meeting specifications of DNV, GL, PTB and TNO. The silencer operates on the combination of the reactive/absorption principle. The silencer can be installed in either horizontal or vertical position.

Attenuation	: approx. 35 dB
Design gasvelocity	: 40 – 50 m/s
Maximum temperature	: 750 °C
Construction	: fully welded; mild steel/Cor-ten steel/Stainless steel
Pain system	: 1 layer of heat-resistant silicone coating

ATTENUATION

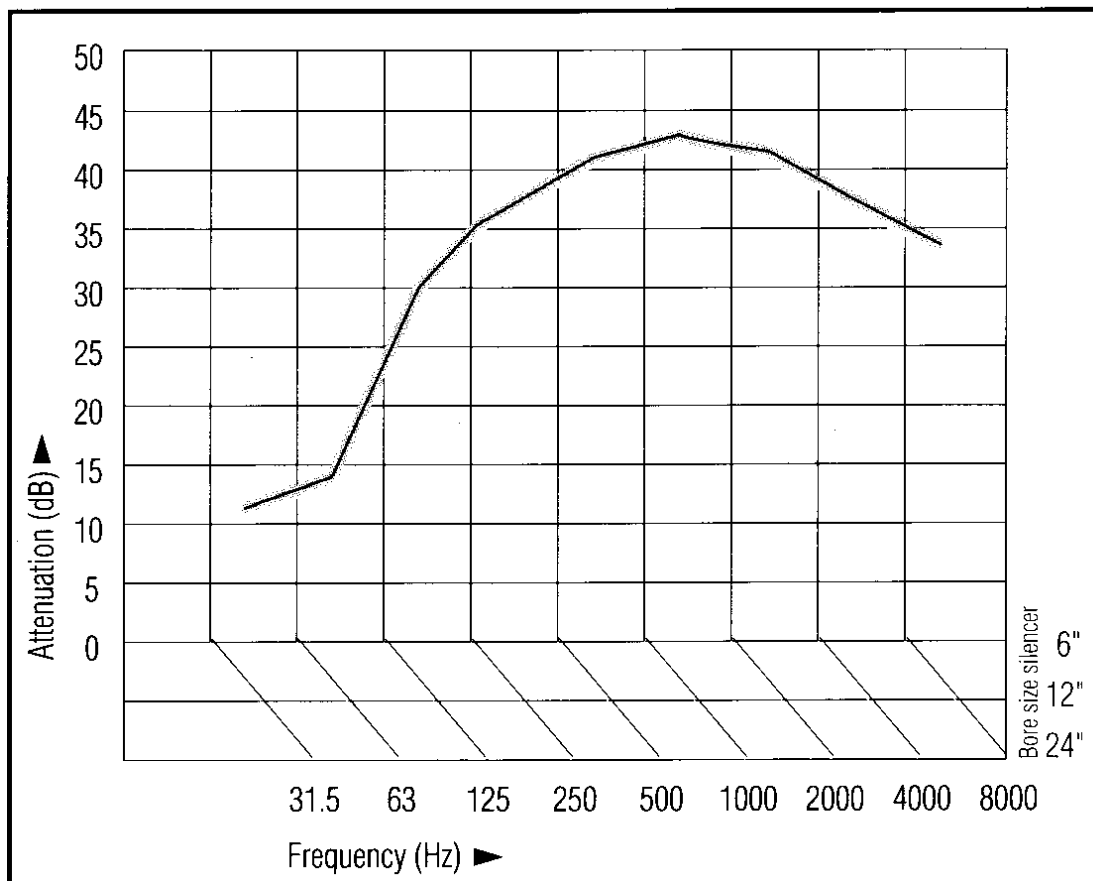

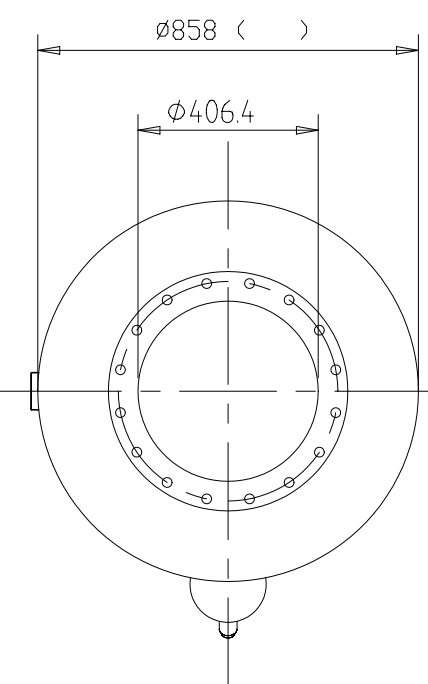
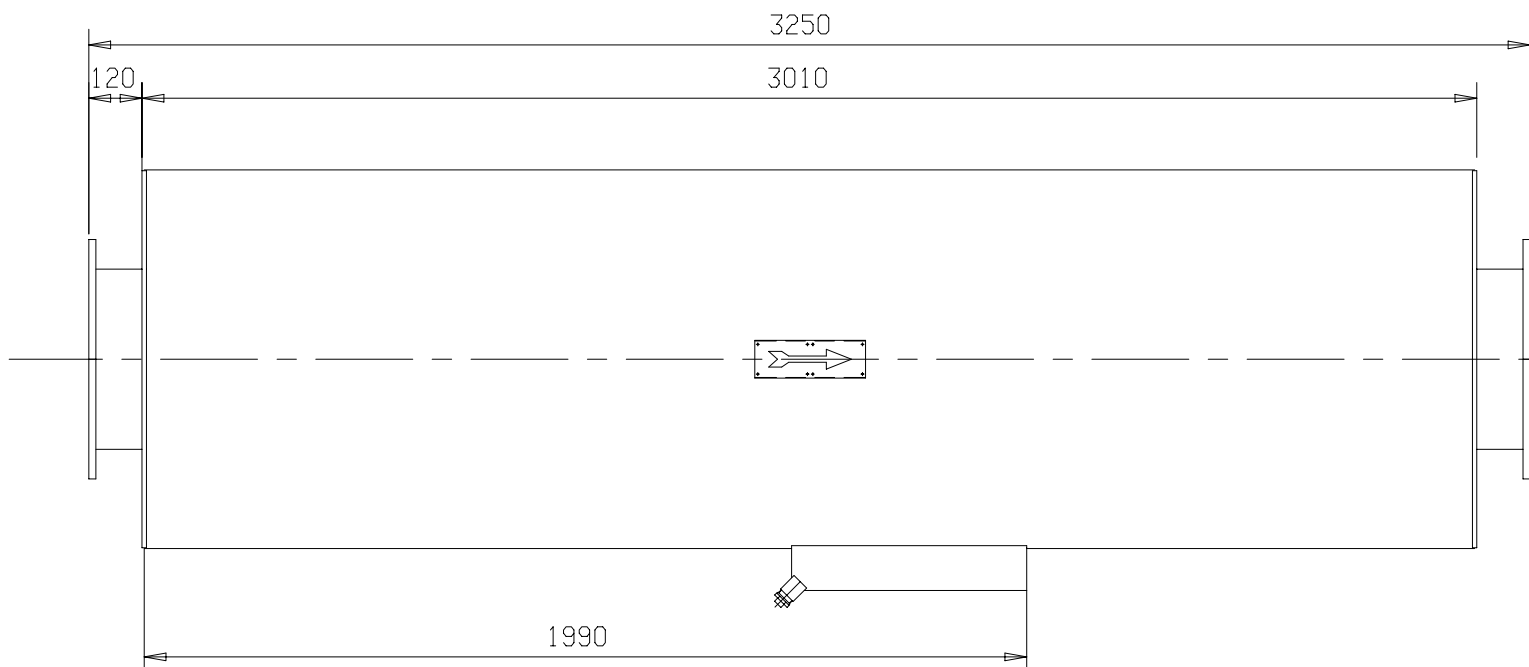

NOTE:
 REFERENCE POINT, FOR DIMENSIONS,
 ALWAYS AT THE INLET SIDE OF THE TUBE

MATERIAL: S235JR G2
 FLANGES: PN6, DINN2573

AB VOLVO PENTA			
SILENCER 16" 35 DB INCL. SPARK ARRESTOR			
			PROJ.
SCALE			TYPE SILENCER KIT NR. 3836181
DRAWN	MV	040601	DRAWING NO.
CHECKED			3836181
APPROVED			SHEET 1
			ISSUE 00