

# STAMFORD®

## HCM636K - Technical Data Sheet

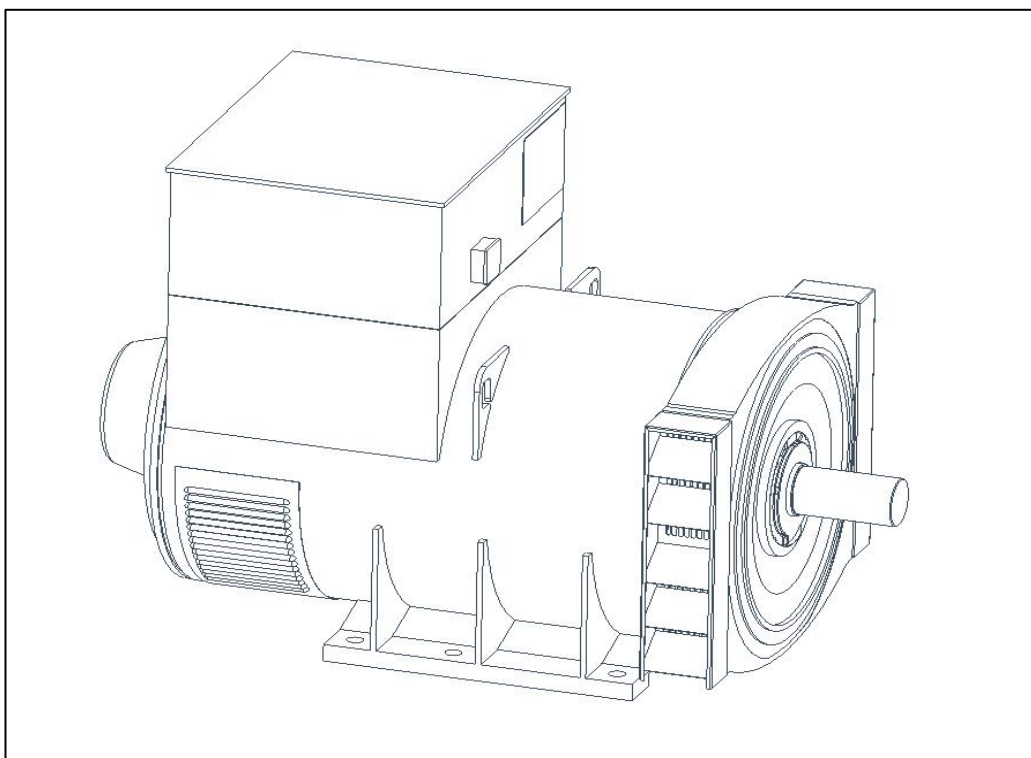

# HCM636K

## SPECIFICATIONS & OPTIONS

**STAMFORD**

### STANDARDS

Marine generators may be certified to Lloyds, DnV, Bureau Veritas, ABS, Germanischer-Lloyd or RINA. Other standards and certifications can be considered on request.

### VOLTAGE REGULATORS

#### MX321 AVR - STANDARD

This sophisticated Automatic Voltage Regulator (AVR) is incorporated into the Stamford Permanent Magnet Generator (PMG) system and is fitted as standard to generators of this type.

The PMG provides power via the AVR to the main exciter, giving a source of constant excitation power independent of generator output. The main exciter output is then fed to the main rotor, through a full wave bridge, protected by a surge suppressor. The AVR has in-built protection against sustained over-excitation, caused by internal or external faults. This de-excites the machine after a minimum of 5 seconds.

Over voltage protection is built-in and short circuit current level adjustment is an optional facility.

### WINDINGS & ELECTRICAL PERFORMANCE

All generator stators are wound to 2/3 pitch. This eliminates triplen (3rd, 9th, 15th ...) harmonics on the voltage waveform and is found to be the optimum design for trouble-free supply of non-linear loads. The 2/3 pitch design avoids excessive neutral currents sometimes seen with higher winding pitches, when in parallel with the mains. A fully connected damper winding reduces oscillations during paralleling. This winding, with the 2/3 pitch and carefully selected pole and tooth designs, ensures very low waveform distortion.

### TERMINALS & TERMINAL BOX

Standard generators feature a main stator with 6 ends brought out to the terminals, which are mounted on the frame at the non-drive end of the generator. A sheet steel terminal box contains the AVR and provides ample space for the customers' wiring and gland arrangements. It has removable panels for easy access.

### SHAFT & KEYS

All generator rotors are dynamically balanced to better than BS6861:Part 1 Grade 2.5 for minimum vibration in operation. Two bearing generators are balanced with a half key.

### INSULATION/IMPREGNATION

The insulation system is class 'H'.

All wound components are impregnated with materials and processes designed specifically to provide the high build required for static windings and the high mechanical strength required for rotating components.

### QUALITY ASSURANCE

Generators are manufactured using production procedures having a quality assurance level to BS EN ISO 9001.

The stated voltage regulation may not be maintained in the presence of certain radio transmitted signals. Any change in performance will fall within the limits of Criteria 'B' of EN 61000-6-2:2001. At no time will the steady-state voltage regulation exceed 2%.

*NB Continuous development of our products entitles us to change specification details without notice, therefore they must not be regarded as binding.*

*Front cover drawing typical of product range.*

# HCM636K



## WINDING 312

CONTROL SYSTEM	SEPARATELY EXCITED BY P.M.G.							
A.V.R.	MX321							
VOLTAGE REGULATION	± 0.5 %	With 4% ENGINE GOVERNING						
SUSTAINED SHORT CIRCUIT	REFER TO SHORT CIRCUIT DECREMENT CURVES (page 7)							
INSULATION SYSTEM	CLASS H							
PROTECTION	IP23							
RATED POWER FACTOR	0.8							
STATOR WINDING	DOUBLE LAYER LAP							
WINDING PITCH	TWO THIRDS							
WINDING LEADS	6							
STATOR WDG. RESISTANCE	0.0039 Ohms PER PHASE AT 22°C STAR CONNECTED							
ROTOR WDG. RESISTANCE	1.75 Ohms at 22°C							
EXCITER STATOR RESISTANCE	17 Ohms at 22°C							
EXCITER ROTOR RESISTANCE	0.1 Ohms PER PHASE AT 22°C							
R.F.I. SUPPRESSION	BS EN 61000-6-2 & BS EN 61000-6-4, VDE 0875G, VDE 0875N. refer to factory for others							
WAVEFORM DISTORTION	NO LOAD < 1.5% NON-DISTORTING BALANCED LINEAR LOAD < 5.0%							
MAXIMUM OVERSPEED	1500 Rev/Min							
BEARING DRIVE END	BALL. 6224 (ISO)							
BEARING NON-DRIVE END	BALL. 6317 (ISO)							
	1 BEARING				2 BEARING			
WEIGHT COMP. GENERATOR	2307 kg				2276 kg			
WEIGHT WOUND STATOR	1078 kg				1008 kg			
WEIGHT WOUND ROTOR	1025 kg				1005 kg			
WR <sup>2</sup> INERTIA	27.7814 kgm <sup>2</sup>				27.2379 kgm <sup>2</sup>			
SHIPPING WEIGHTS in a crate	2367 kg				2336 kg			
PACKING CRATE SIZE	194 x 92 x 147(cm)				194 x 92 x 147(cm)			
	50 Hz				60 Hz			
TELEPHONE INTERFERENCE	THF<2%				TIF<50			
COOLING AIR	1.614 m <sup>3</sup> /sec 3420 cfm				1.961 m <sup>3</sup> /sec 4156 cfm			
VOLTAGE STAR	380/220	400/231	415/240	440/254	416/240	440/254	460/266	480/277
VOLTAGE DELTA	220	230	240	254	240	254	266	277
KVA BASE RATING FOR REACTANCE VALUES	505	505	505	505	594	625	625	625
X <sub>d</sub> DIR. AXIS SYNCHRONOUS	1.52	1.36	1.28	1.13	1.77	1.65	1.52	1.39
X' <sub>d</sub> DIR. AXIS TRANSIENT	0.15	0.13	0.12	0.11	0.18	0.16	0.16	0.14
X'' <sub>d</sub> DIR. AXIS SUBTRANSIENT	0.12	0.11	0.11	0.10	0.15	0.14	0.12	0.11
X <sub>q</sub> QUAD. AXIS REACTANCE	0.95	0.86	0.79	0.71	1.10	1.03	0.95	0.87
X'' <sub>q</sub> QUAD. AXIS SUBTRANSIENT	0.13	0.12	0.11	0.10	0.16	0.15	0.13	0.12
X <sub>L</sub> LEAKAGE REACTANCE	0.05	0.05	0.04	0.04	0.07	0.06	0.05	0.05
X <sub>2</sub> NEGATIVE SEQUENCE	0.13	0.12	0.11	0.10	0.16	0.15	0.13	0.12
X <sub>0</sub> ZERO SEQUENCE	0.09	0.08	0.07	0.06	0.10	0.10	0.09	0.08
REACTANCES ARE SATURATED				VALUES ARE PER UNIT AT RATING AND VOLTAGE INDICATED				
T' <sub>d</sub> TRANSIENT TIME CONST.	0.12 s							
T'' <sub>d</sub> SUB-TRANSTIME CONST.	0.016 s							
T' <sub>do</sub> O.C. FIELD TIME CONST.	1.15 s							
T <sub>a</sub> ARMATURE TIME CONST.	0.04 s							
SHORT CIRCUIT RATIO	1/X <sub>d</sub>							

50  
Hz

HCM636K  
Winding 312

STAMFORD

THREE PHASE EFFICIENCY CURVES

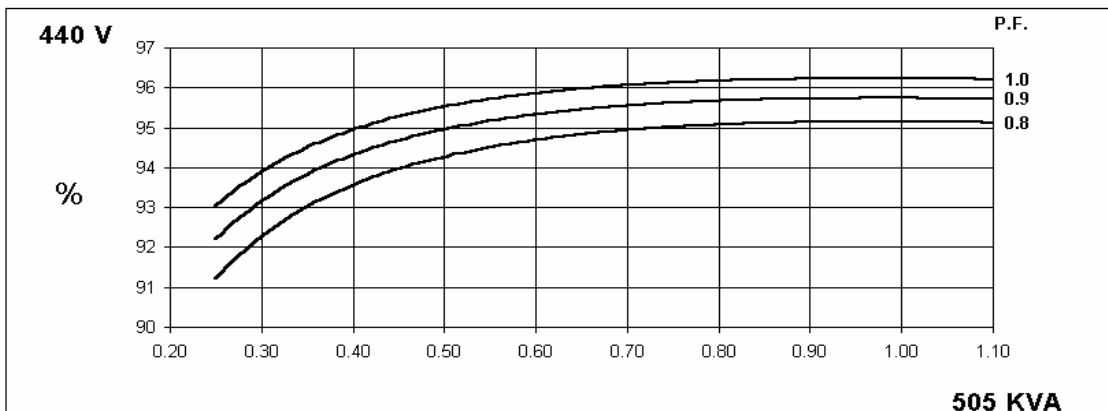
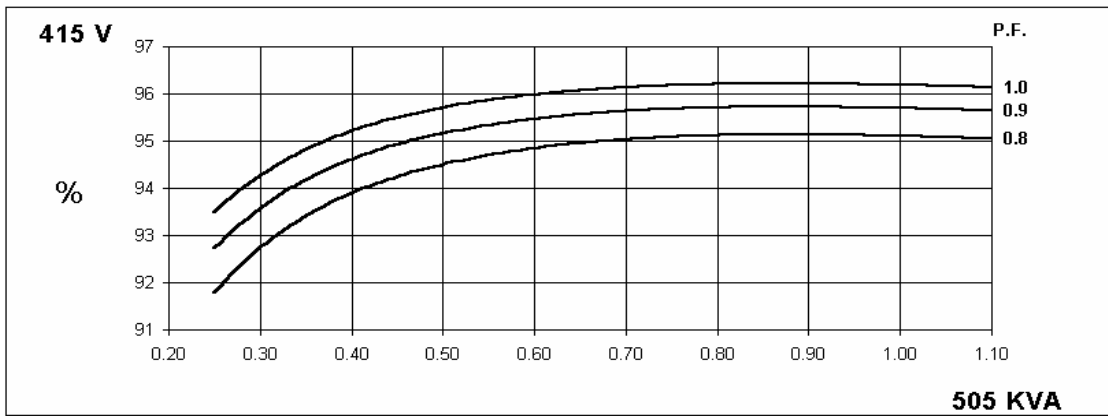
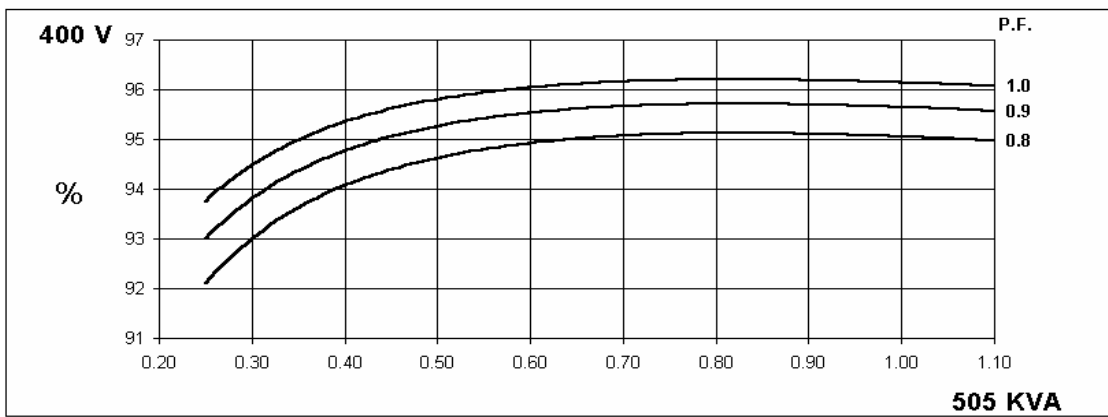
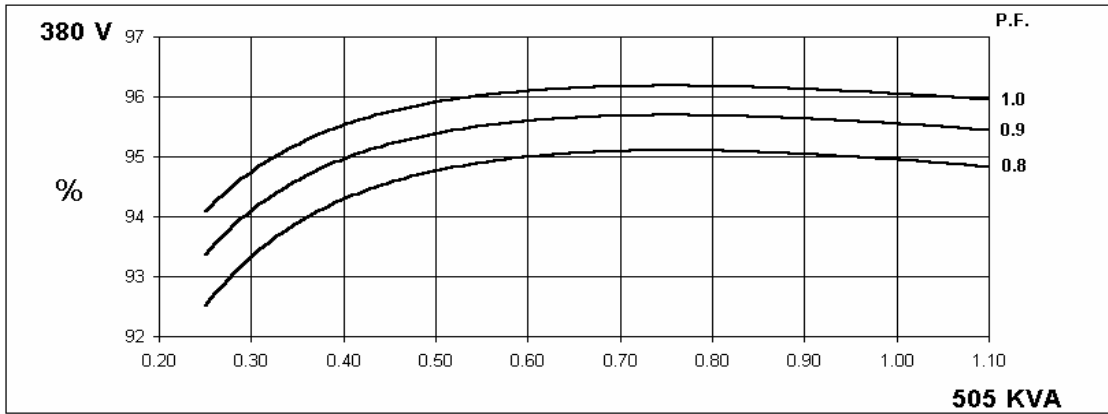

60  
Hz

HCM636K  
Winding 312

STAMFORD

THREE PHASE EFFICIENCY CURVES

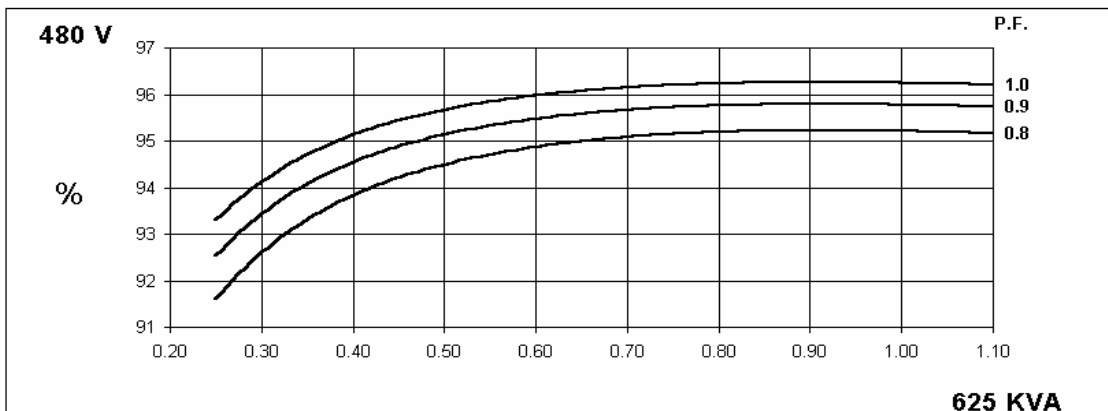
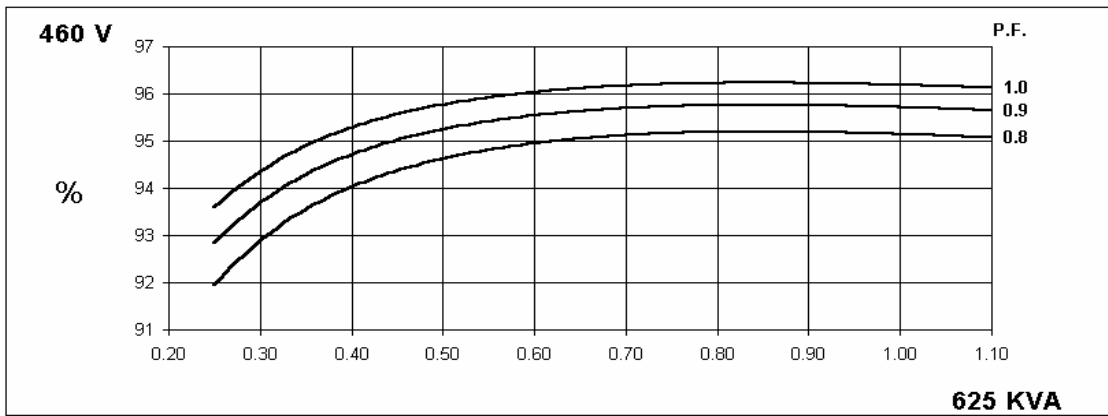
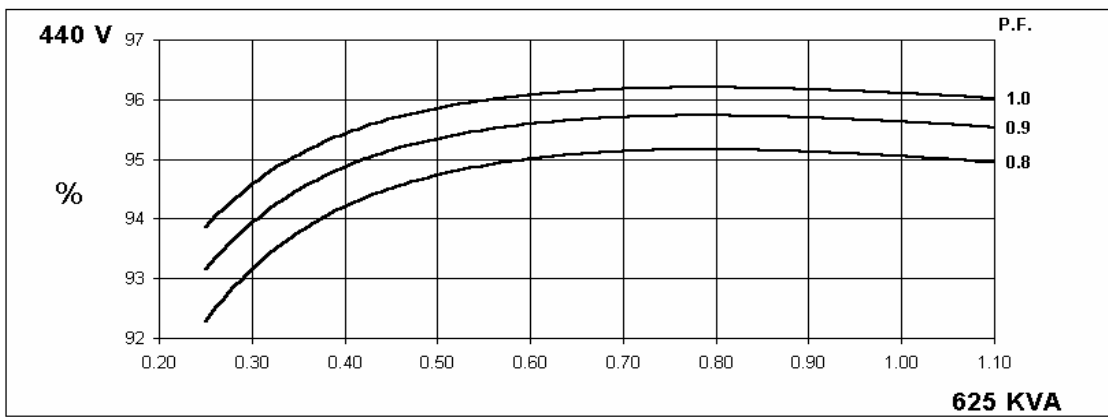
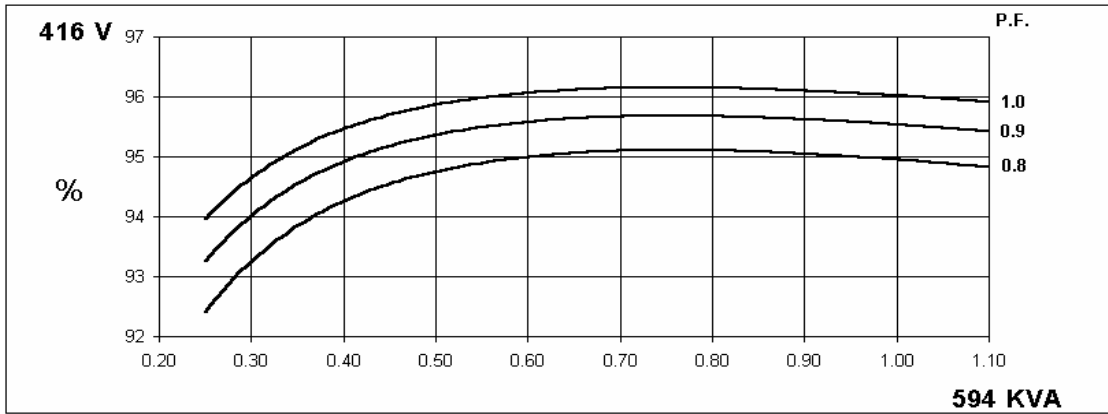

HCM636K  
Winding 312

STAMFORD

Locked Rotor Motor Starting Curve

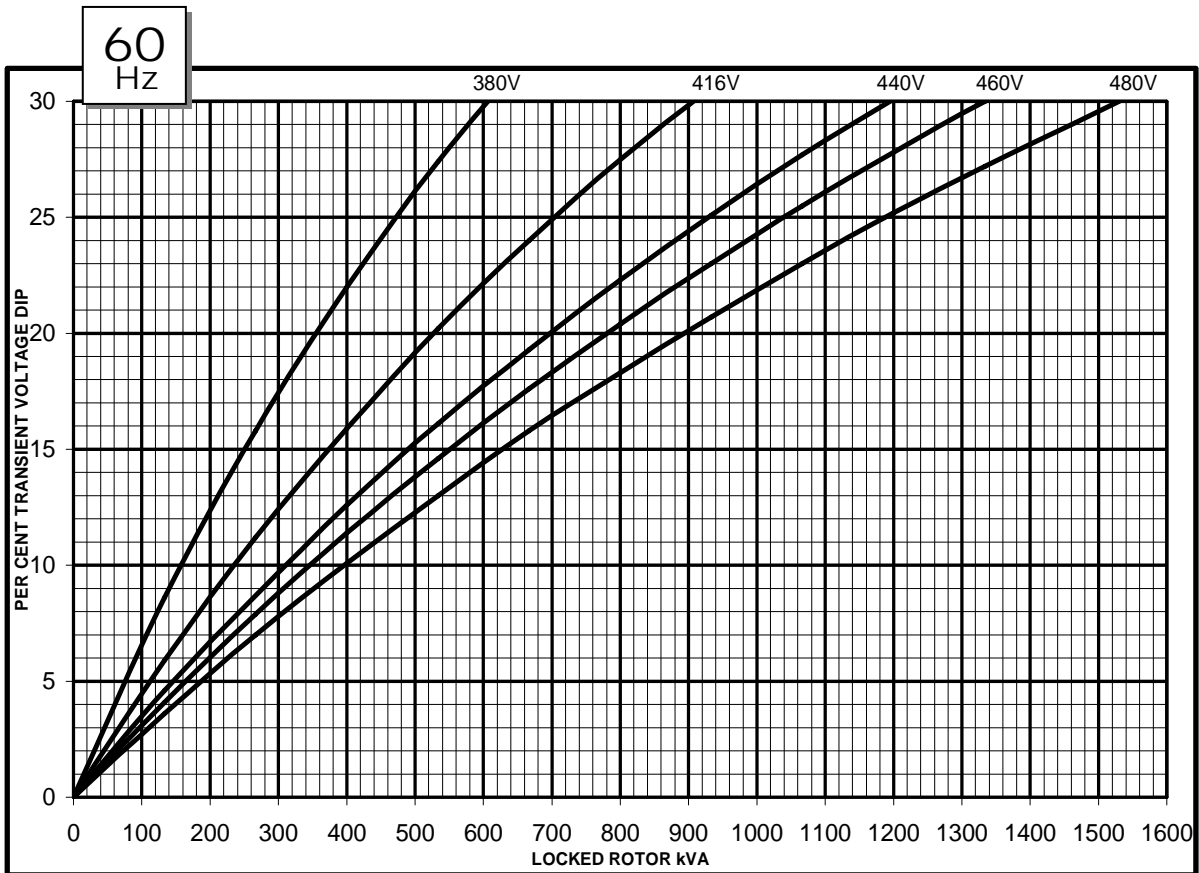
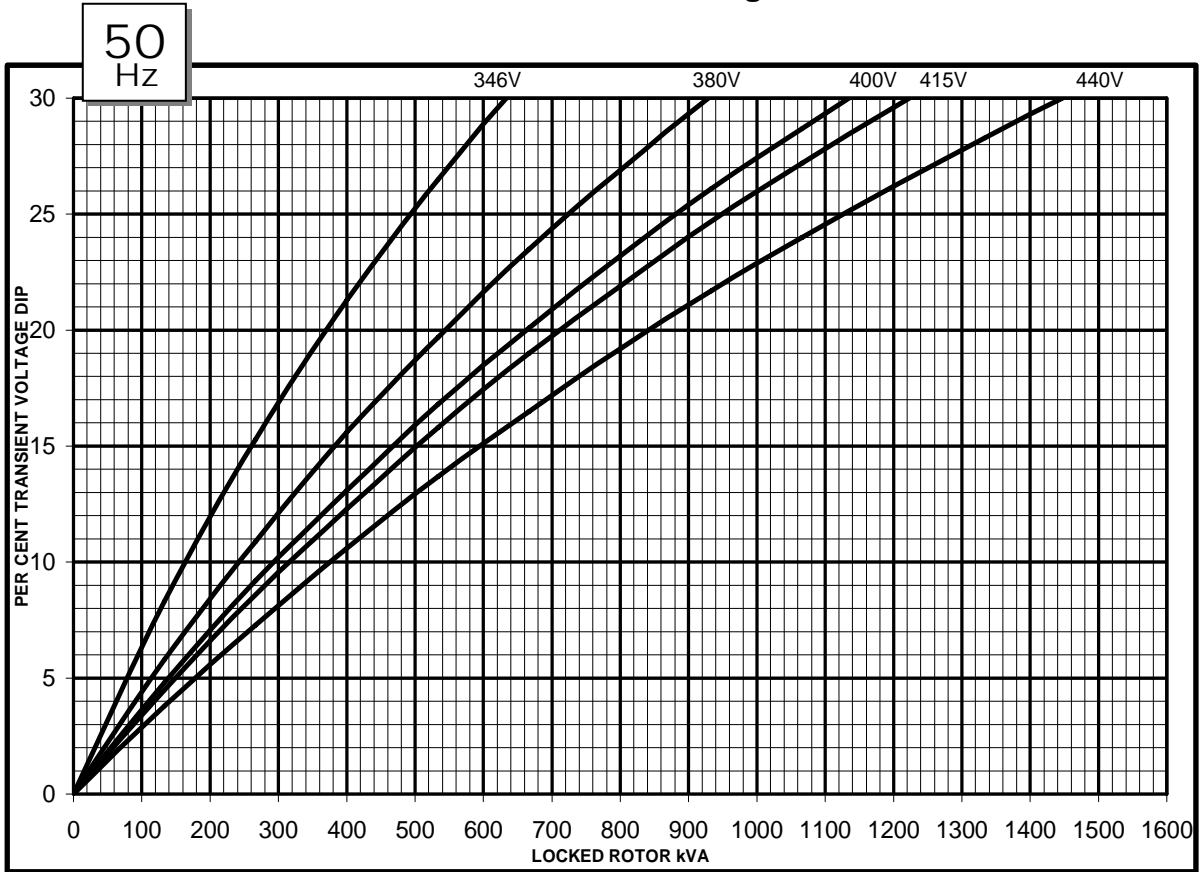

**Three-phase Short Circuit Decrement Curve. No-load Excitation at Rated Speed  
Based on star (wye) connection.**

50  
Hz

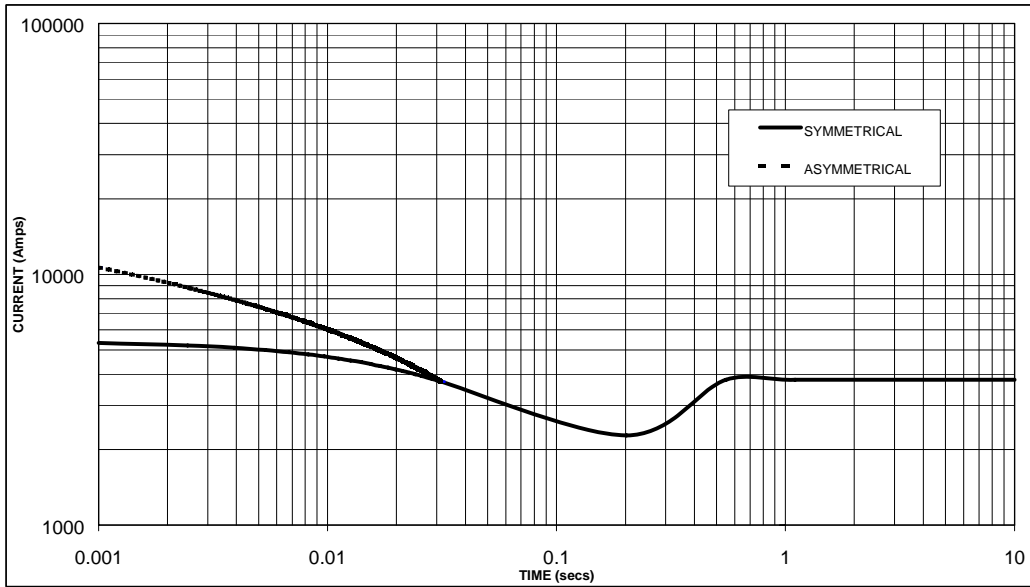

Sustained Short Circuit = 3,800 Amps

60  
Hz

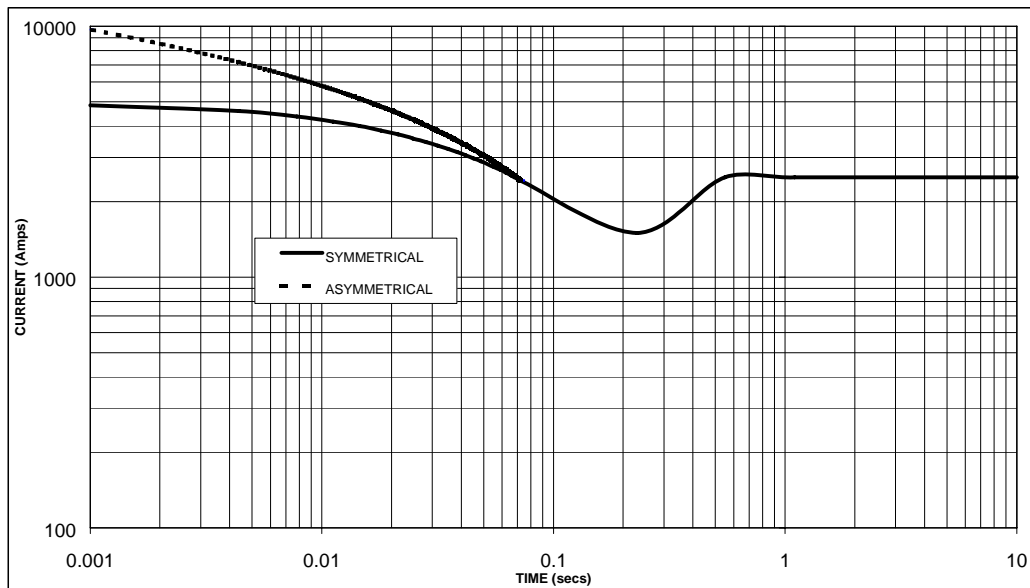

Sustained Short Circuit = 2,500 Amps

**Note 1**

The following multiplication factors should be used to adjust the values from curve between time 0.001 seconds and the minimum current point in respect of nominal operating voltage :

50Hz		60Hz	
Voltage	Factor	Voltage	Factor
380v	X 1.00	416v	X 1.00
400v	X 1.07	440v	X 1.06
415v	X 1.12	460v	X 1.12
440v	X 1.18	480v	X 1.17

The sustained current value is constant irrespective of voltage level

**Note 2**

The following multiplication factor should be used to convert the values calculated in accordance with NOTE 1 to those applicable to the various types of short circuit :

	3-phase	2-phase L-L	1-phase L-N
Instantaneous	x 1.00	x 0.87	x 1.30
Minimum	x 1.00	x 1.80	x 3.20
Sustained	x 1.00	x 1.50	x 2.50
Max. sustained duration	10 sec.	5 sec.	2 sec.

All other times are unchanged

**Note 3**

Curves are drawn for Star (Wye) connected machines. For Delta connection multiply the Curve current value by 1.732

**HCM636K**  
**Winding 312 / 0.8 Power Factor**

**RATINGS**

Class - Temp Rise		Cont. E - 65/50°C				Cont. B - 70/50°C				Cont. F - 90/50°C				Cont. H - 110/50°C			
<b>50 Hz</b>	Star (V)	380	400	415	440	380	400	415	440	380	400	415	440	380	400	415	440
	Delta (V)	220	230	240	254	220	230	240	254	220	230	240	254	220	230	240	254
	kVA	R.T.F.	R.T.F.	R.T.F.	R.T.F.	440	440	440	440	505	505	505	505	505	505	505	505
	kW	R.T.F.	R.T.F.	R.T.F.	R.T.F.	352	352	352	352	404	404	404	404	404	404	404	404
	Efficiency (%)	R.T.F.	R.T.F.	R.T.F.	R.T.F.	95.1	95.1	95.1	95.1	95.0	95.1	95.1	95.1	95.0	95.1	95.1	95.1
	kW Input	R.T.F.	R.T.F.	R.T.F.	R.T.F.	370	370	370	370	425	425	425	425	425	425	425	425

<b>60 Hz</b>	Star (V)	416	440	460	480	416	440	460	480	416	440	460	480	416	440	460	480
	Delta (V)	240	254	266	277	240	254	266	277	240	254	266	277	240	254	266	277
	kVA	R.T.F.	R.T.F.	R.T.F.	R.T.F.	510	535	535	535	594	625	625	625	594	625	625	625
	kW	R.T.F.	R.T.F.	R.T.F.	R.T.F.	408	428	428	428	475	500	500	500	475	500	500	500
	Efficiency (%)	R.T.F.	R.T.F.	R.T.F.	R.T.F.	95.1	95.1	95.2	95.2	95.0	95.1	95.1	95.2	95.0	95.1	95.1	95.2
	kW Input	R.T.F.	R.T.F.	R.T.F.	R.T.F.	429	450	450	450	500	526	526	525	500	526	526	525

**DIMENSIONS**

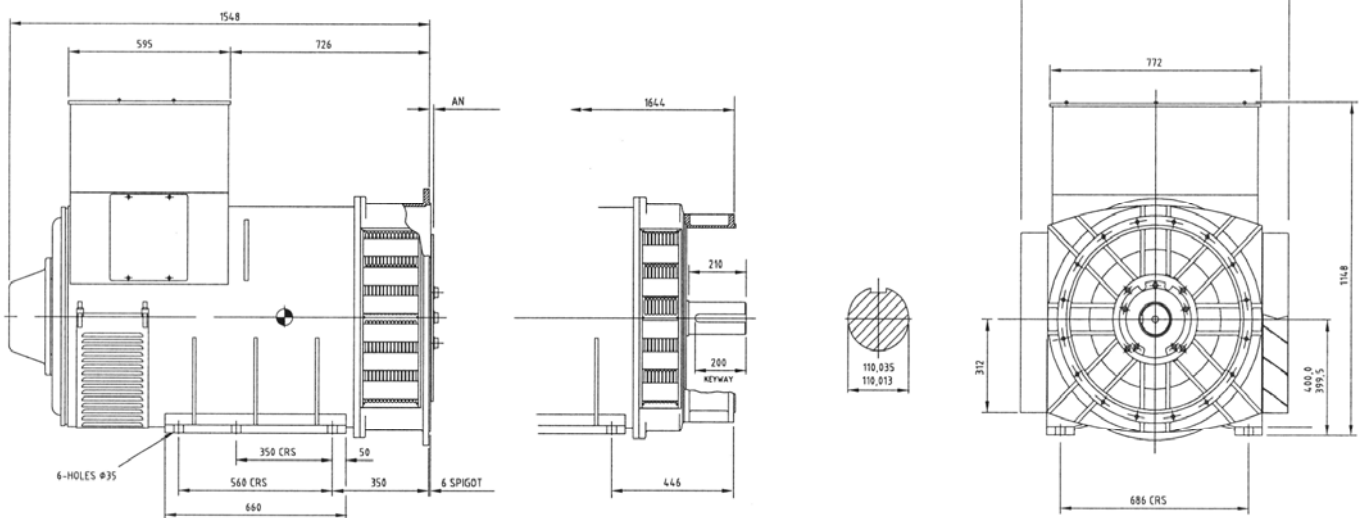

COUPLING DISC	AN
SAE 14	25.4
SAE 18	15.87
SAE 21	0
SAE 24	0