

POWER HOUSE MARINE GENSET

PHD9 MG

170–282 kVA (136–225 kW) at 1500rpm 50Hz/400V, 213–313 kVA (170–250 kW) at 1800rpm 60Hz/440V

Power House Genset system

The Power House Genset systems are the complete solution for a ship's onboard power requirements. You will not only get reliable marine diesels, well-matched generators and a monitoring system, but also a wide range of products and services to optimize your investment.

Each Power House Genset is built fully adapted to the customer's requirements and comes complete and tested, ready for installation onboard. The basis for the Power House Gensets is the smooth running and reliable marine diesel engines. Compact in design, they occupy less space in the engine room, and their good accessibility makes service and maintenance easy. Auto-start and synchronizing is rapid and reliable, meeting all standards with a comfortable margin.

All the Power House Gensets are type approved by the major classification societies and can be delivered under complete certification.

Engine

The Volvo Penta engines are well balanced and have excellent emission performance. With growing care for the environment all over the world, emission regulations are becoming increasingly stricter. The D9 MG engine is certified for IMO NOx and the comprehensive emission requirements EPA Tier 2, and EU IWW.

Volvo's basic engine design in combination with a highly efficient speed control system gives superior load taking capability.

Generator

All the standard Gensets are equipped with a generator built by Newage Stamford. Stamford is the market leader in this power range and provides for worldwide service coverage. These generators are of a long proven design, based on years of experience of power generation for land-based and marine applications.

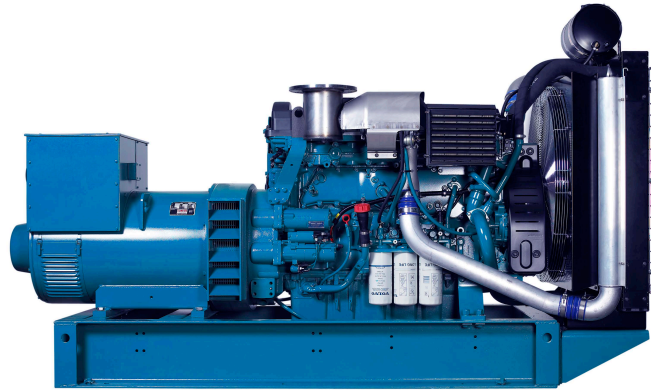

Technical Data Engine

Engine brand	Volvo Penta	
Engine designation.	D9 MG	
No. of cylinders and configuration.	in-line 6	
Method of operation.	4-stroke, direct-injected, turbocharged	
.....	diesel engine with aftercooler	
Bore, mm	120	
Stroke, mm	138	
Displacement, l	9.4	
Compression ratio.	20.2:1	
.....	1500 rpm	1800 rpm
Crankshaft Power HE Cooling, kW	239	265
Crankshaft Power RC Cooling, kW	227	244
Crankshaft Power KC Cooling, kW	239	265
Specific fuel consumption, g/kWh.	213 (50%)	218 (50%)
.....	205 (75%)	208 (75%)
.....	204 (100%)	206 (100%)
Recommended fuel to conform to.	ASTM-D975 1-D & 2-D, EN 590 or	
.....	JIS KK 2204	

10% overload available acc. to class requirements. Fuel temperature 40°C (104°F). Technical data according to ISO 3046 Fuel Stop Power with a tolerance ±4%. Fuel with a lower calorific value of 42700 kJ/kg and density of 840 g/liter at 15°C (60°F). Merchant fuel may differ from this specification which will influence engine power output and fuel consumption. The engine is certified according to IMO NOx, EPA Tier 2 and EU IWW.

PHD9 MG

Technical description

Complete Genset

- High system efficiency as a result of system optimization of the complete Genset
- All used components of highest quality from well reputed suppliers
- Reinforced set dimensioned for high output and low sound level
- Mono-block engine/generator rigidly mounted on a common bed frame
- Engine directly coupled to generator via a flexplate
- Flexible mountings including welding plates mounted under the frame

Engine and block

- Cylinder block and cylinder head made of cast iron
- One piece cylinder head
- Replaceable wet cylinder liners and valve seats/guides
- Drop forged crankshaft with induction hardened bearing surfaces and fillets with seven main bearings
- Four valve per cylinder layout with over-head camshaft
- Each cylinder features cross-flow inlet and exhaust ducts
- Gallery oil cooled forged aluminum pistons, three piston rings (keystone top ring)
- Senders for oil pressure (after filter), oil temp, oil pressure piston cooling, oil level, fuel pressure, freshwater pressure, exhaust temp, crankcase pressure, speed crank and cam, boost pressure/temp, seawater pressure (HE), coolant level, coolant temp, water in fuel (not classifiable)

Lubrication system

- Freshwater-cooled oil cooler integrated in cylinder block
- Twin full flow oil filter of spin-on type and single by-pass filter

Fuel system

- Electronic Unit Injectors
- Gear-driven fuel pump, driven by timing gear
- Electronically controlled injection timing
- 5-hole high pressure injector nozzles
- Single engine-mounted fine fuel filter of spin-on type, with water separator and water in fuel sensor

Turbocharger

- Dry twin entry turbocharger

Heat Exchanger cooled system (HE)

- For seawater- and central-cooled Gensets
- Engine-mounted tubular heat exchanger with expansion tank
- Belt-driven centrifugal fresh water pump
- Gear-driven rubber impeller raw water pump

Radiator cooled system (RC)

- For air-cooled Gensets
- V-belt-driven radiator fan
- Belt-driven centrifugal fresh water pump
- Expansion tank mounted on radiator
- Air to air CAC (Charge Air Cooler)

Keel cooled system (KC)

- 2-circuit cooling system
- Belt-driven centrifugal fresh water pump in HT circuit
- Engine mounted expansion tank in HT circuit
- Gear driven rubber impeller fresh water pump in CAC LT circuit

Generator

- 4-pole, brushless, AC marine generator
- Temperature rise class F
- Tropical insulation class H
- Stator winding as standard with short 2/3 pitch winding, ideal for non-linear load (thyristor load)
- Automatic Voltage Regulator (AVR) for accurate voltage regulation
- Permanent magnet mounted on generator for independent power supply to AVR
- Single bearing generator as standard
- Voltage available range up to 690V
- IP23 enclosure as standard
- Anti condensation heating

Control System

- MCC a flexible and expandable control and monitoring system for classified installations. Incl. separate safety shutdown system
- Meets classification requirements of separate shutdown and monitoring system
- Easy to interface with leading suppliers of ship control systems
- Possibility to connect relays for remote control functions (potential free contacts)
- Classifiable by all major classification societies

Optional equipment

Engine

- Twin engine-mounted fine fuel filter of spin-on type with change over valve
- Twin fuel pre-filters/water separator with change over valve
- Flexible exhaust compensator
- Cooling water connection bellows
- Electrical, air or hydraulic starting systems in various combinations
- Raw water pressure indication (only in combination with raw water pump)
- Exhaust temperature indication
- Engine heater 2000W

Generator

- Air inlet filters according to IP23
- Air inlet louvres/filters according to IP44
- Parallel equipment mounted in generator
- Thermistors (1 or 2 per phase) mounted in generator for temperature measurement of windings in generator
- PT100 elements (1 or 2 per phase) mounted in generator for temperature measurement of windings in generator
- Double bearing generator (on request)
- PT100 elements mounted in generator bearings for temperature measurement

Miscellaneous

- Dry exhaust silencer with or without spark arrestor
- 80A alternator with integrated charging sensor
- **Basic toolkit**
- Spare parts according to classification recommendations

Contact your local Power House dealer for further information.

Not all models, standard equipment and accessories are available in all countries. All specifications are subject to change without notice.

The Genset illustrated may not be entirely identical to production standard Gensets.

PHD9 MG

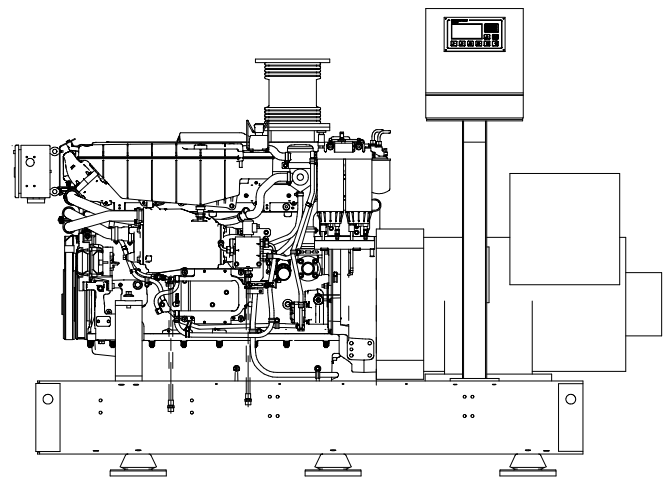
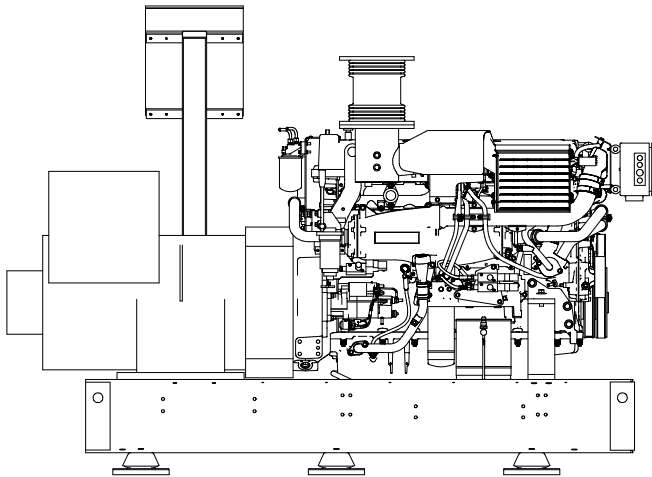

Technical Data HE Genset

Power output at 1500 rpm 50Hz/400V, kVA (kWe)

PHD9 MG / HCM434C-1	210 (168)
PHD9 MG / HCM434D-1	230 (184)
PHD9 MG / HCM434E-1	275 (220)
PHD9 MG / HCM434F-1	282 (225)

Power output at 1800 rpm 60Hz/440V, kVA (kWe)

PHD9 MG / UCM274H-1	213 (170)
PHD9 MG / HCM434C-1	245 (196)
PHD9 MG / HCM434D-1	270 (216)
PHD9 MG / HCM434E-1	313 (250)

10% overload available according to class requirements. Fuel temperature 40°C (104°F). Technical data according to ISO 3046 Fuel Stop Power and ISO 8665. Fuel with a lower calorific value of 42700 kJ/kg and density of 840 g/liter at 15°C (60°F). Merchant fuel may differ from this specification which will influence engine power output and fuel consumption.

Dimensions L x W x H₁/H₂ (mm), not for installation

PHD9 MG / UCM274H-1	2492 x 1161 x 1712/1919
PHD9 MG / HCM434C-1	2660 x 1161 x 1712/1919
PHD9 MG / HCM434D-1	2660 x 1161 x 1712/1919
PHD9 MG / HCM434E-1	2660 x 1161 x 1712/1919
PHD9 MG / HCM434F-1	2750 x 1161 x 1712/1919

Weight, kg

PHD9 MG / UCM274H-1	2260
PHD9 MG / HCM434C-1	2480
PHD9 MG / HCM434D-1	2570
PHD9 MG / HCM434E-1	2655
PHD9 MG / HCM434F-1	2790

H₁ = Height including exhaust compensator H₂ = Total genset height including control box

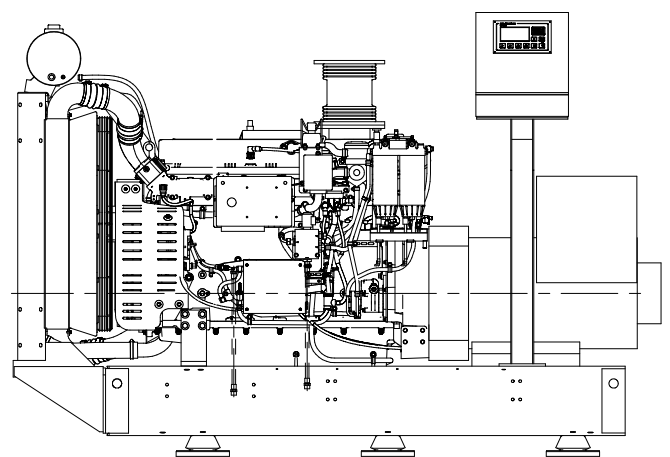
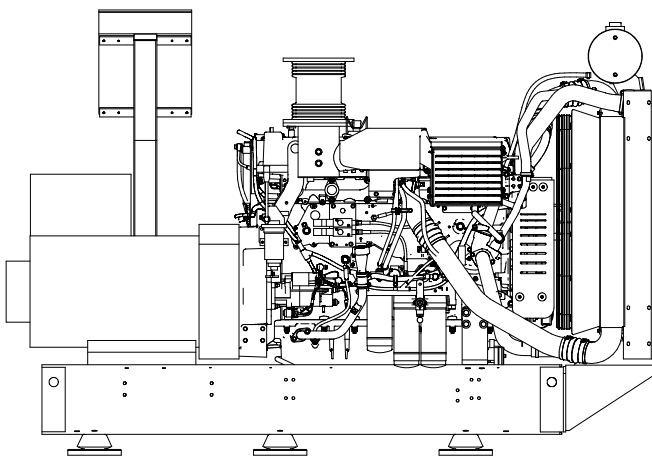

Technical Data RC Genset

Power output at 1500 rpm 50Hz/400V, kVA (kWe)

PHD9 MG / UCM274H-1	170 (136)
PHD9 MG / HCM434C-1	210 (168)
PHD9 MG / HCM434D-1	230 (184)
PHD9 MG / HCM434E-1	268 (214)

Power output at 1800 rpm 60Hz/440V, kVA (kWe)

PHD9 MG / UCM274H-1	213 (170)
PHD9 MG / HCM434C-1	245 (196)
PHD9 MG / HCM434D-1	270 (216)
PHD9 MG / HCM434E-1	288 (230)

10% overload available according to class requirements. Fuel temperature 40°C (104°F). Technical data according to ISO 3046 Fuel Stop Power and ISO 8665. Fuel with a lower calorific value of 42700 kJ/kg and density of 840 g/liter at 15°C (60°F). Merchant fuel may differ from this specification which will influence engine power output and fuel consumption.

Dimensions L x W x H₁/H₂ (mm), not for installation

PHD9 MG / UCM274H-1	2801 x 1165 x 1712/1919
PHD9 MG / UCM434C-1	2969 x 1165 x 1712/1919
PHD9 MG / HCM434D-1	2969 x 1165 x 1712/1919
PHD9 MG / HCM434E-1	2969 x 1165 x 1712/1919

Weight, kg

PHD9 MG / UCM274H-1	2210
PHD9 MG / HCM434C-1	2430
PHD9 MG / HCM434D-1	2520
PHD9 MG / HCM434E-1	2605

H₁ = Height including exhaust compensator H₂ = Total genset height including control box

PHD9 MG

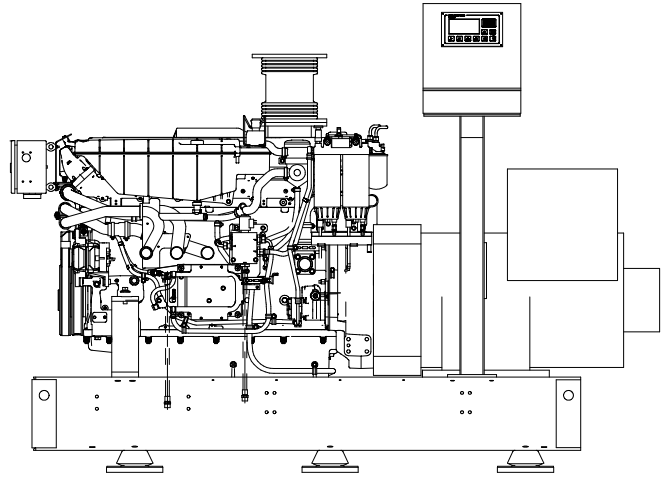
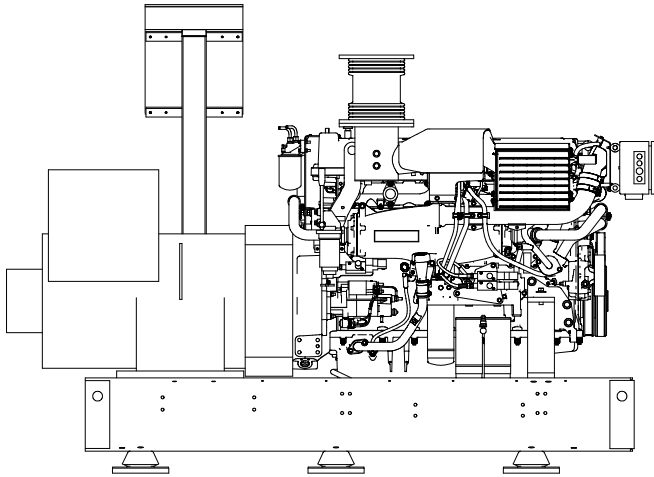

Technical Data KC Genset

Power output at 1500 rpm 50Hz/400V, kVA (kWe)	
PHD9 MG / HCM434C-1.....	210 (168)
PHD9 MG / HCM434D-1.....	230 (184)
PHD9 MG / HCM434E-1.....	275 (220)
PHD9 MG / HCM434F-1.....	282 (225)
Power output at 1800 rpm 60Hz/440V, kVA (kWe)	
PHD9 MG / UCM274H-1.....	213 (170)
PHD9 MG / HCM434C-1.....	245 (196)
PHD9 MG / HCM434D-1.....	270 (216)
PHD9 MG / HCM434E-1.....	313 (250)

10% overload available according to class requirements. Fuel temperature 40°C (104°F). Technical data according to ISO 3046 Fuel Stop Power and ISO 8665. Fuel with a lower calorific value of 42700 kJ/kg and density of 840 g/liter at 15°C (60°F). Merchant fuel may differ from this specification which will influence engine power output and fuel consumption.

Dimensions L x W x H ₁ /H ₂ (mm), not for installation	
PHD9 MG / UCM274H-1.....	2492 x 1161 x 1712/1919
PHD9 MG / HCM434C-1.....	2660 x 1161 x 1712/1919
PHD9 MG / HCM434D-1.....	2660 x 1161 x 1712/1919
PHD9 MG / HCM434E-1.....	2660 x 1161 x 1712/1919
PHD9 MG / HCM434F-1.....	2750 x 1161 x 1712/1919
Weight, kg	
PHD9 MG / UCM274H-1.....	2160
PHD9 MG / HCM434C-1.....	2380
PHD9 MG / HCM434D-1.....	2470
PHD9 MG / HCM434E-1.....	2555
PHD9 MG / HCM434F-1.....	2690

H₁ = Height including exhaust compensator
H₂ = Total genset height including control box