

Data sheet

EMP 2 Pressure transmitters



The high accuracy pressure transmitter EMP 2 is designed for monitoring and control in marine and industrial applications and offers a reliable pressure measurement, even under harsh environmental conditions.

The flexible pressure transmitter programme covers absolute or gauge (relative) versions with zero and span adjustment with a 4 – 20 mA output signal.

It has all the necessary marine approvals.

Special versions with integrated pulse-snubber available, designed for use in hydraulic applications with severe medium influences like cavitation, liquid hammer or pressure peaks.

* For use in zone 2 explosive atmospheres.

Features

- For use in Zone 2 explosive atmosphere

Approvals

Lloyds Register of Shipping, LRS
 Germanischer Lloyd, GL
 Det Norske Veritas, DNV
 Registro Italiano Navale, RINA
 Bureau Veritas, BV

Nippon Kaiji Kyokai, NKK
 American Bureau of Shipping, ABS
 Korean Register of Shipping, KR
 China Classification Society, CCS
 Russian Maritime Register of Shipping, RMRS

Technical data
Performance (EN 60770)

Sensor temperature range	Normal	-10 – 70 °C, (Ref. Fig. 1)	
	ATEX Zone 2	-10 – 85 °C	
Transport / storage temperature	-50 – 70 °C		
Media temperature	-40 – 100 °C, (Ref. Fig. 1)		
Media	Water, fuel, oil, lubricating oil, refrigerants, ammonia, gas etc.		
Voltage supply	Max. 32 V and min. 12 V d.c. between terminals N and P		
Load resistance	A. max. 410 Ω at 24 V d.c. 50% / -20%		
	B. max. 650 Ω at 24 V d.c. 50% / 0%		
Zero point adjustment	- 5 – 20% range span; but max. -1–1.5 bar (kp/cm ²)		
Span adjustment	± 5% of range span; max. ± 5 bar (kp/cm ²)		
Combination of span and zero point adjustments	- 5 – 20% of range span		
Noise – immunity	Complies with the standard for industrial apparatus EN 61000-6-2. The standard contains tests for the following: HF fields, mains transmitted HF, voltage transients, electrostatic immunity, supply voltage variations, low-frequency radiation and transient protection in accordance with Germanischer Lloyd		
Noise – emission	Complies with standard EN 61000-6-3		
Accuracy			< 0.3 % of FS
	In vacuum (below 0 bar)		< 2.3 % of FS
Temperature dependence	Thermal zero point shift	≤ ± 0.06 % FS / °C	
	Thermal sensitivity (span) shift	≤ ± 0.06 % FS / °C	
Voltage dependence	≤ ± 0.1% FS / 10 V		
Vibration stability	3 – 30 Hz amplitude 1.13 mm and 30 – 300 Hz acceleration 4G according to IEC 60068-2-6. The requirements of the ship classification societies are up to 100 Hz, acceleration 4G. Extended specifications by prior arrangement		
Time constant	Liquids with viscosity < 100 cSt	< 4 ms	
	Air and gas in combination with pulse snubber:	< 35 ms	
Shock stability	500 g for 1 ms to IEC 60068-2-27		
Enclosure	IP67 Housings are made of enamelled pressure-die-cast aluminium (GD-AISI 12)		
Pressure connection	G ¼, G ½ A standard, G ¾ A mano		
Net weight	approx. 1 kg		
Cable entry	Pg 13.5 for cable diameters 5 – 14 mm		

Explosive atmospheres

Zone 2 applications	II 3G Ex nA IIA T3 Gc -20C<Ta<+85C	EN60079-0; EN60079-15
---------------------	---	-----------------------

When used in ATEX Zone 2 areas at temperatures <-10 °C the cable and plug must be protected against impact

Identification

The type designation and code number of the transmitter is embossed on the side of the housing at the bottom close to the pressure connector.

Ordering

(When ordering please state type and code number)

Pressure in bar

Operating pressure p_e [bar]	Test pressure p_e [bar]	Min. burst pressure p_e [bar]	Code no. EMP 2	
			G ½ A	G ¾ A
-1 – 1.5 ²⁾	5	100	084G2100	–
-1 – 5 ²⁾	35	200	084G2101	–
0.2 – 1	3.2	100	084G2102	–
0 – 1.6	3.2	100	084G2104	–
0 – 2.5	5	200	084G2105	–
0 – 4	8	200	084G2106	084G2206
0 – 6	18	400	084G2107	084G2207
0 – 6	60 ¹⁾	400	084G2108	–
0 – 10	20	400	084G2109	084G2209
0 – 10	60 ¹⁾	400	084G2110	–
0 – 16	32	400	084G2111	084G2211
0 – 25	50	400	084G2112	–
0 – 40	80	400	084G2113	084G2213
0 – 60	120	400	084G2114	–
0 – 100	200	400	084G2115	–
0 – 160	260	640	084G2116	–
0 – 250	375	1000	084G2117	–
-1 – 9 ²⁾	20	400	084G2120	–

¹⁾ With pulse snubber

²⁾ Sealed gauge

Pressure in kp/cm²

Operating pressure p_e [kp/cm ²]	Test pressure p_e [kp/cm ²]	Min. burst pressure p_e [kp/cm ²]	Code no. EMP 2	
			G ½ A	G ¾ A
-1 – 5 ²⁾	35	200	084G2131	–
0 – 4	8	200	084G2136	084G2157
0 – 6	18	400	084G2137	084G2158
0 – 10	20	400	–	084G2179
0 – 15	32	400	084G2141	084G2159
0 – 25	50	400	084G2142	–
0 – 40	80	400	084G2143	084G2169
0 – 50	120	400	084G2144	–
0 – 20	50	400	084G2154	–

¹⁾ With pulse snubber

²⁾ Sealed gauge

Installation conditions

Max. ambient temperature as a function of temperature

- A: Ambient temperature
- B: Temperature and medium
- C: Operating range
- D: Transport and storage temperature

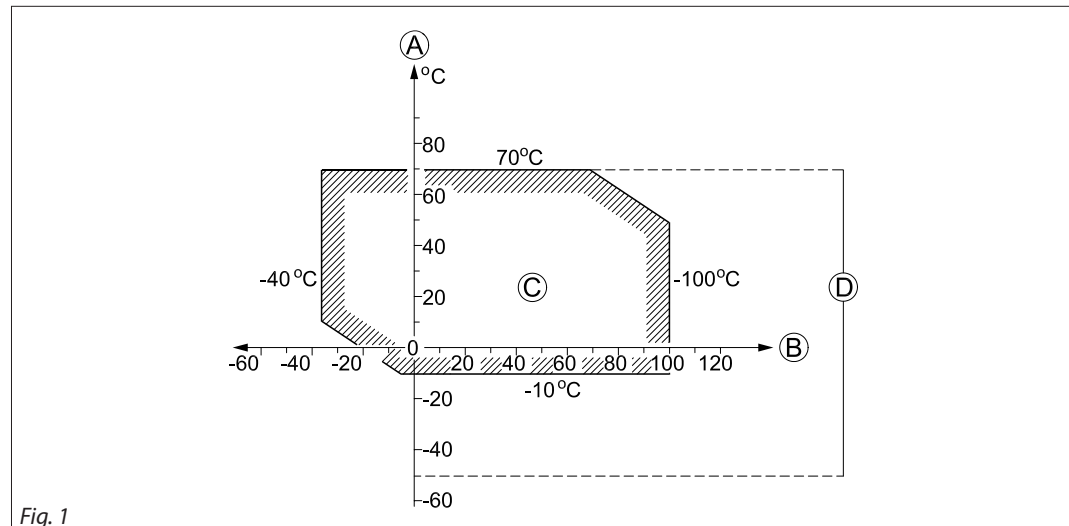

Fig. 1

Mounting

Type EMP 2 is equipped with a 3 mm steel bracket for mounting.

Pressure connection

Connector with outside cylindrical thread G 1/2, some types available with G 3/8 A mano, and inside cylindrical thread G 1/4, to ISO 228.

The primary insertion length of the connector corresponds to EN 837. Connection to the transmitter is made through a connector with a spanner flat, 14 mm across flats.

When fitting or removing pressure lines, the spanner flats on the pressure connector should be used to apply counter-torque.

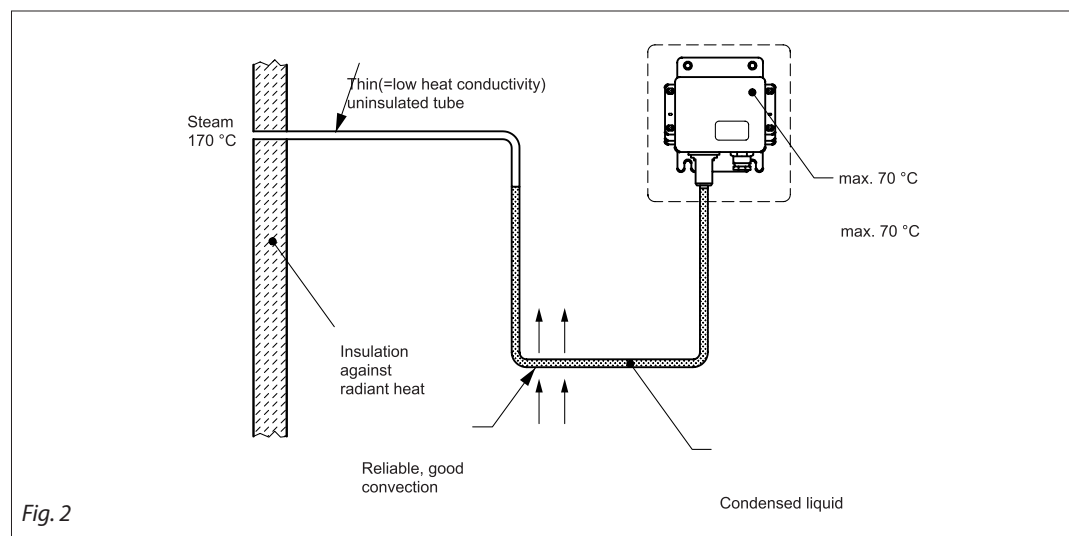

Fig. 2

Water systems

Water in the pressure element is not harmful, but in the event of frost a water-filled pressure element may burst. To prevent this the transmitter should be allowed to operate on an air cushion.

Steam plant

To protect the pressure element against temperatures in excess of the maximum temperature for the medium (100 °C), the insertion of a water-filled loop is recommended. In the example, fig. 2, insulation against radiant heat is also shown.

Application and media conditions

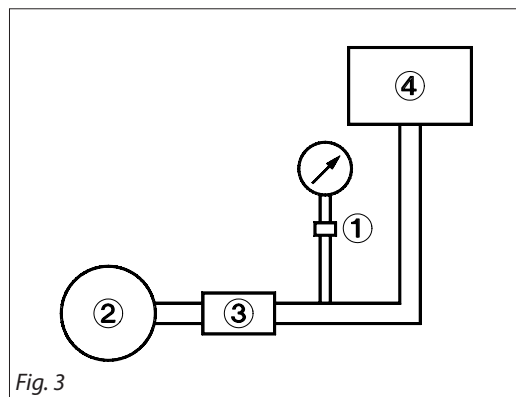

Fig. 3

- 1: Surge damper
- 2: Pump
- 3: Valve
- 4: Tank

In cases where valves are closed momentarily, surges of a value in excess of that for which the pressure element is designed can occur. To avoid damage to the pressure element, a damper should be fitted.

The device can consist of a flexible pipe, a throttle, a shock valve, or a combination of these items. The amplitude of surges should never exceed the maximum pressure range of the pressure transmitter.

Electrical connection

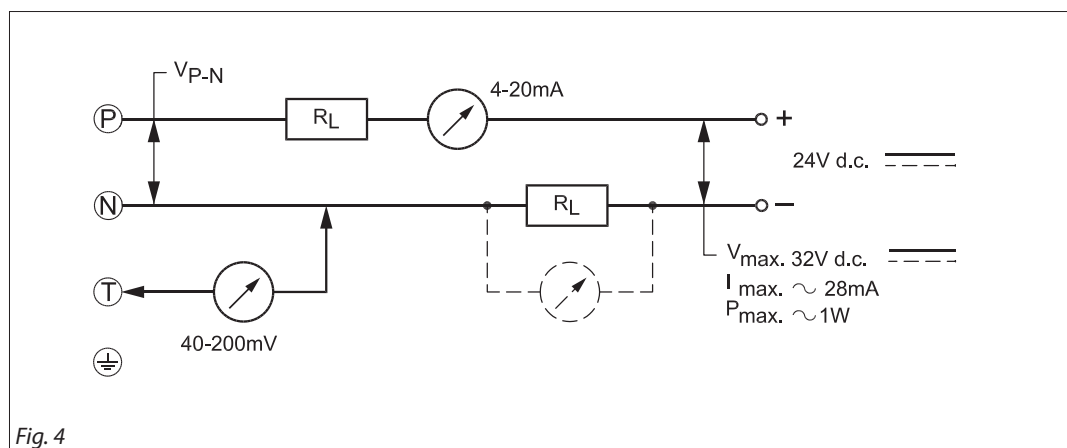
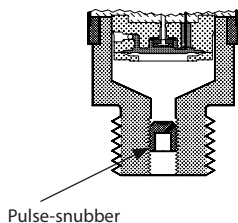

Fig. 4

The transmitter has a wiring diagram, see fig. 4. Terminals P (positive) and N (negative) are connection terminals for the supply voltage.

The same leads are used for supply voltage and output signal. A function test can be performed between terminals N and T without cutting off the current loop.

Pulse snubber



EMP 2 with the pressure range 0 – 6 bar and 0 – 10 bar at extended test pressure is provided with an integrated pulse snubber for protection of the sensor element against cavitations and air bubbles in the media due to extreme pressure peaks and pulsations. Such conditions may be caused by pumps or fast operation valves in both high and low pressure systems.

The integrated pulse snubber is designed as an 0.3 mm orifice mounted in the pressure connection. The medium should not contain particles which may clog up in the orifice. The viscosity has only little effect on the response time. Even at liquid viscosities up to 100 Cst the response time will not exceed 4 ms.

Dimensions and weight

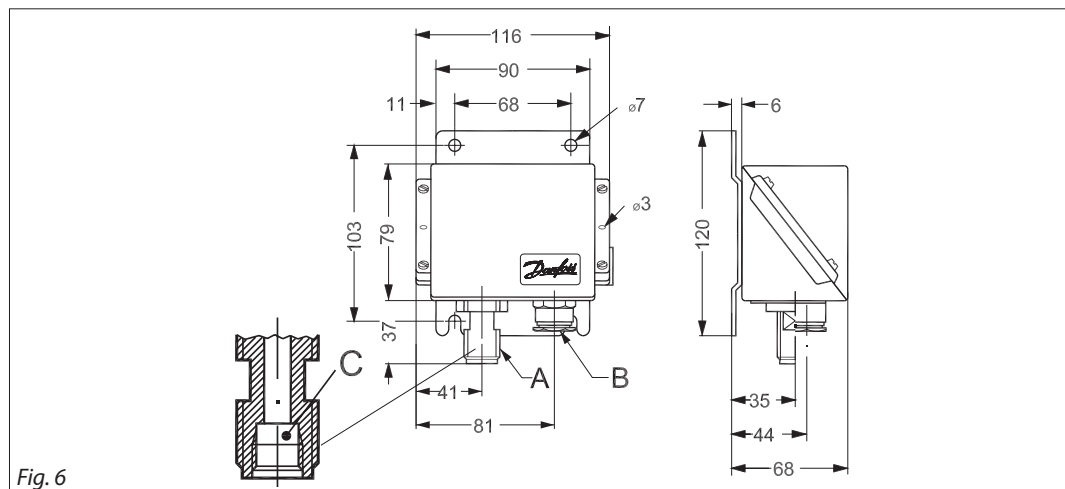

A: G 1/2 A (G 3/8 A mano)
 B: Pg 13.5
 C: G 1/4
 Net weight 1 kg

Fig. 6

Accessories

Part	Symbol	Description	Material	Code no.
Damping coil		Damping coil with G 3/8 unions and 1.5 m copper capillary tube.	Copper	060-104766
Damping coil		Damping coil with G 1/2 unions and 1 m capillary tube. Standard washers supplied	Stainless steel	060-016966
Damping coil, armoured		Damping coil with G 3/8 unions and 1 m armoured copper capillary tube. Standard washers supplied	Copper	060-333366
Nipple		G 1/4 A x G 3/8A with copper washer	Brass	060-333266
		G 1/4 A x M10 ext. x 1 with copper washer	Brass	060-333866

Conversion table

	Pascal (= Newton per square metre) [N/m ²] Pa	Newton per square [mm] [N/mm ²]	[bar]	Kilopond per square metre [mm] H ₂ O [kp/m ²]	Meter water gauge [m] H ₂ O	Technical atmosphere [kp/cm ²] [at]	Physical atmosphere [atm]	Torr [0 °C] [mm] Hg	Inches Hg [0 °C] [in] Hg	Poundforce per Square inch [lbf/in ²] psi
1 Pa	1	10 ⁻⁶	10 ⁻⁵	0.1020	1.020 · 10 ⁻⁴	1.020 · 10 ⁻⁵	9.869 · 10 ⁻⁵	7.500 · 10 ⁻³	2.953 · 10 ⁻⁴	1.450 · 10 ⁻⁴
1 N/mm ²	10 ⁶	1	10	1.020 · 10 ⁵	10.20	10.20	9.869	7.5 · 10 ³	295.3	145.0
1 bar	10 ⁵	0.1	1	10.197 · 10 ³	10.20	1.020	0.9869	750	29.53	14.50
1 kp/m ²	9.80665	9.807 · 10 ⁻⁶	9.807 · 10 ⁻⁵	1	10 ⁻³	10 ⁻⁴	0.9678 · 10 ⁻⁴	0.07355	2.896 · 10 ⁻³	1.422 · 10 ⁻³
1 m H ₂ O	9806.7	9.807 · 10 ³	0.09807	1000	1	0.1	0.09678	73.55	2.896	1.422
1 at	98.066 · 10 ³	0.09807	0.9807	10 ⁴	10	1	0.9678	735.5	28.96	14.22
1 atm	101.325 · 10 ³	0.1013	1.013	10.333 · 10 ³	10.33	1.033	1	760	29.92	14.70
1 mm Hg	133.32	1.333 · 10 ⁻⁴	1.333 · 10 ⁻³	13.60	0.01360	1.360 · 10 ⁻³	1.316 · 10 ⁻³	1	0.03937	1.934 · 10 ⁻²
1 in Hg	3387	3.387 · 10 ⁻³	0.03387	345.3	0.3453	0.03453	0.03342	25.4	1	0.4912
1 psi	6895	6.895 · 10 ⁻³	0.06895	703.1	0.7031	0.07031	0.06804	51.71	2.036	1

Danfoss can accept no responsibility for possible errors in catalogues, brochures and other printed material. Danfoss reserves the right to alter its products without notice. This also applies to products already on order provided that such alterations can be made without consequential changes being necessary in specifications already agreed. All trademarks in this material are property of the respective companies. Danfoss and the Danfoss logotype are trademarks of Danfoss A/S. All rights reserved.