



mitsubishi S6R2-T2MPTK-1-2

Click on the headlines below to get redirected to the respective sections in this document.

[Technical data](#)
[Elastic drawing](#)
[Flywheel & housing drawing](#)
[Measure of overhaul](#)
[Connection details](#)
[Performance curves](#)



**MITSUBISHI DIESEL ENGINE
TECHNICAL INFORMATION**

ITEM NO.	T0209-0012E Rev.2 (1/4)
DATE	Nov., 2010

Specification Sheets of S6R2-T2MPTK Engine (IMO-Tier 2 Certified Engine)

Specification Sheets of S6R2-T2MPTK Engine that is satisfied with IMO-Tier 2 certified engine are enclosed herein.

Revision	First Edition : Nov., 2010	Engine Engineering Department Engine System Design Section		
	Rev.1 : Jun., 2011			
	Rev.2 : June, 2012	Approved by	Checked by	Drawn by

GENERAL ENGINE DATA

Type	-----	4-Cycle, Water Cooled	
Aspiration	-----	Turbo-Charged, Inter Cooler	
		(Raw water to Cooler)	
Cylinder Arrangement	-----	Inline	
No. of Cylinders	-----	6	
Bore mm(in.)	-----	170	(6.69)
Stroke mm(in.)	-----	220	(8.66)
Displacement Liter(in. ³)	-----	29.96	(1828)
Compression Ratio	-----	14.0 : 1	
Dry Weight - Engine only - kg(lb)	-----	2960	(6527)
Wet Weight - Engine only - kg(lb)	-----	3150	(6946)

PERFORMANCE DATA

Steady State Speed Stability Band at any Constant Load(Generator Use)

Hydraulic (std.) or Electric Governor - %	-----	±0.25 or better	
Idling Speed -rpm	-----	600~650	
Maximum Overspeed Capacity - rpm	-----	1750	
Moment of Inertia of Rotating Components J- kg·m ² (lbf·ft ²)	-----	11.96	(1135)
(Includes 18 inch Flywheel)			
Cyclic Speed Variation with Flywheel at	1500rpm -----	1/116	
	1200rpm -----	1/76	

ENGINE MOUNTING

Maximum Bending Moment at Rear Face of Flywheel Housing - N·m(lbf·ft)	-----	1961	(1447)
---	-------	------	--------

AIR INLET SYSTEM

Maximum Intake Air Restriction (Includes piping)- kPa (in.H ₂ O)	-----	3.92	(15.7)
Maximum Allowable Intake Air Temperature- °C (°F)	-----	45	(113)

EXHAUST SYSTEM

Maximum Allowable Back Pressure - kPa (in.H ₂ O)	-----	4.41	(17.7)
---	-------	------	--------

LUBRICATION SYSTEM

Oil Pressure at Idle - MPa (psi)	-----	0.2~0.3	(29~43)
at Rate Speed - MPa (psi)	-----	0.5~0.64	(71~93)
Standard Thermostat (Modulating)Range- °C (°F)	-----	82~95	(180~203)
Maximum Oil Temperature- °C (°F)	-----	110	(230)
Oil Capacity of Marine Pan High - liter (U.S.gal)	-----	140	(37.0)
Low - liter (U.S.gal)	-----	110	(29.1)
Total System Capacity (Includes Oil Filter) - liter (U.S.gal)	-----	160	(42.3)
Maximum Installation Angle	Front Up -----	8°	
	Front Down -----	8°	
Maximum Instantaneous Operating Angle	Front Up -----	25°	
(Engine Level)	Front Down -----	15°	
	Side to Side -----	22.5°	

COOLING SYSTEM

Coolant Capacity - liter (U.S.gal)	-----	55	(14.5)
(Engine only)			
Maximum External Friction Head at Engine Outlet-MPa(psi)	-----	0.034	(5.0)
Recommended Static Head of Coolant above Crankshaft Center - m(ft)			
	MAX. -----	10	(32.8)
	MIN. -----	7	(23.0)
Standard Thermostat (Modulating)Range- °C (°F)	-----	71~85	(160~185)
Maximum Coolant Temperature at Engine Outlet- °C (°F)	-----	95	(203)
Recommended Coolant Temperature at Engine outlet- °C (°F)	-----	80	(176)
Minimum Coolant Expansion Space-% of System Capacity	-----	10	
Maximum Coolant Temperature at Inter Cooler Inlet, TK type- °C (°F)	-----	see page 4/4	

The specifications are subject to change without notice.

APPLICATION : MARINE

Pub. No. T0209-0012E Rev.2 2/4

FUEL SYSTEM

Fuel Injection Pump	----- Mitsubishi PS6 Type x 1
Maximum Suction Head of Feed Pump - kPa (in. Hg)	----- 14.7 (4.3)
Maximum Level of Fuel Tank - m	----- 5.0
Continuous Use	----- 5.0
Stand-by Use	----- 2.0
Minimum Fuel Oil Supply Pipe Inner Diameter - mm(in.)	----- 16 (0.63)
Minimum Fuel Oil Leak Pipe Inner Diameter - mm(in.)	----- 16 (0.63)

STARTING SYSTEM

Battery Charging Alternator - V-Ah	----- 24-35
Starting Motor Capacity - V -kW	----- 24-7.5
Maximum Allowable Resistance of Cranking Circuit - m Ω	----- 2.5
Recommended Minimum Battery Capacity	
At 5°C (41°F) and above - Ah	----- 200
Below 5°C (41°F) through -5°C (23°F)	----- 500
Cranking Ampere of Starter at 5°C (41°F) / -5°C (23°F)	
Static Ampere -A	370 / 500
Momentary Ampere -A	700 / 960

ACCESSORY EQUIPMENT

Air Cleaner	Silencer Type
Exhaust Manifold	Water Cooled
Turbocharger	Air cooled
Air Cooler	Raw Water Cooled
Breather	Conduction Type
Governor	Hydraulic PSG Type
Fuel Injection Pump	
Fuel Feed Pump	
Fuel Injection Pipe	Double walled Type
Fuel Injection Nozzle	
Fuel Filter	Paper Element Type
Lubricating Oil Pump	
Lubricating Oil Cooler	
Lubricating Oil Filter(Full-Flow)	Paper Element Type
Lubricating Oil Filter(By-Pass Flow)	Paper Element Type
Oil Pan	Large Capacity,steel
Lubricating Oil Thermostat	
Cooling Water Pump	
Cooling Water Thermostat	
Starter	Earth Float Type
Alternator	Earth Float Type
Stop Solenoid	DC24V-15A
Engine Support	Marine Type
Accessory Drive	Front Drive Pulley

The specifications are subject to change without notice.

ENGINE RATING

All data represent net performance according to ISO3046 with standard accessories such as fuel injection pump, water pump L.O. pump and charging alternator under the condition of 100kPa(750 mm Hg), barometric pressure 298K(25°C) ambient temperature and 30% relative humidity.

ITEM	UNIT	Propulsion use				Generator use		
		L	M	H	H	50Hz	60Hz	
Engine Speed	min ⁻¹	1500	1400	1350	1350	1500	1200	
Test cycle (ISO 8178)		E3	E3	E3	E2	D2	D2	
No. of Cylinders		6						
Bore	mm (in.)	170 (6.69)						
Stroke	mm (in.)	220 (8.66)						
Displacement	liter (in. ³)	29.96 (1828)						
Brake Horse Power	kW (HP)	610 (818)	530 (710)	480 (643)	480 (643)	640 (858)	500 (670)	
Brake Mean Effective Pressure	MPa (psi)	1.63 (236)	1.51 (219)	1.42 (206)	1.42 (206)	1.71 (248)	1.67 (242)	
Mean Piston Speed	m/s (ft/min)	11.0 (2165)	10.3 (2028)	9.9 (1949)	9.9 (1949)	11.0 (2165)	8.8 (1732)	
Maximum Regenerative Power Absorption Capacity	kW (HP)	60 (81)	54 (73)	52 (70)	52 (70)	60 (81)	44 (59)	
Intake Air Flow	m ³ /min (CFM)	56 (1977)	48 (1695)	43 (1518)	43 (1518)	58 (2048)	44 (1554)	
Exhaust Gas Flow	m ³ /min (CFM)	147 (5191)	127 (4484)	114 (4025)	114 (4025)	152 (5367)	115 (4061)	
Coolant Flow	liter/min (U.S. GPM)	820 (217)	760 (201)	730 (193)	730 (193)	820 (217)	650 (172)	
Coolant(Jacket water) Pressure (water pump outlet)	MPa (psi)	0.17 (25)	0.15 (22)	0.14 (21)	0.14 (21)	0.17 (25)	0.11 (16)	
Min. Coolant Flow to Inter Cooler (Max. Flow: 440L/min)	liter/min (U.S. GPM)	150 (40)	150 (40)	150 (40)	150 (40)	150 (40)	150 (40)	
Oil Flow	liter/min (U.S. GPM)	290 (77)	270 (71)	260 (69)	260 (69)	290 (77)	230 (61)	
Radiated Heat to Ambient	kJ/hr (BTU/min)	117048 (1849)	101222 (1599)	90812 (1435)	90812 (1435)	121082 (1913)	91457 (1445)	
Heat Rejection to Coolant (include water cooled manifold)	kJ/hr (BTU/min)	1404571 (22192)	1214662 (19192)	1089742 (17218)	1089742 (17218)	1452989 (22957)	1097489 (17340)	
Heat Rejection to Inter Cooler (TK Version)	kJ/hr (BTU/min)	526714 (8322)	455498 (7197)	408653 (6457)	408653 (6457)	544871 (8609)	411558 (6503)	
Heat Rejection to Exhaust	kJ/hr (BTU/min)	1608501 (25414)	1382106 (21837)	1223743 (19335)	1223743 (19335)	1631658 (25780)	1172740 (18529)	
Cooling system	Direct Sea Water Cooling Max. sea water temp. at inter cooler inlet	Max. 32°C				N/A	Max. 32°C	
	Intermediate Fresh Water Cooling Max. fresh water temp. at inter cooler inlet	N/A	N/A	Max. 38°C (When sea water temp. 32°C)				
	Radiator Cooling Max. coolant temp. at inter cooler inlet	N/A	N/A	N/A	N/A	N/A	N/A	
Noise Level (1 m height & distance) (excludes, Intake, Exhaust)	dB(A)	-	-	-	-	-	-	
Maximum No Load Governed Speed	min ⁻¹	1613	1505	1451	1451	1575	1260	

The specifications are subject to change without notice.

APPLICATION : MARINE

Pub. No. T0209-0012E Rev.2

4/4



**MITSUBISHI DIESEL ENGINE
TECHNICAL INFORMATION**

ITEM NO.

T0307-0027E (1/2)

DATE

April, 2007

Elastic data of S6R2-M Engine

Elastic data of S6R2-M Engine are enclosed herein.

Revision	First Edition : April, 2007 (Refer to MTD00-0019)	Engine Engineering Department Large Engine Design Section		
		Approved by	Checked by	Drawn by

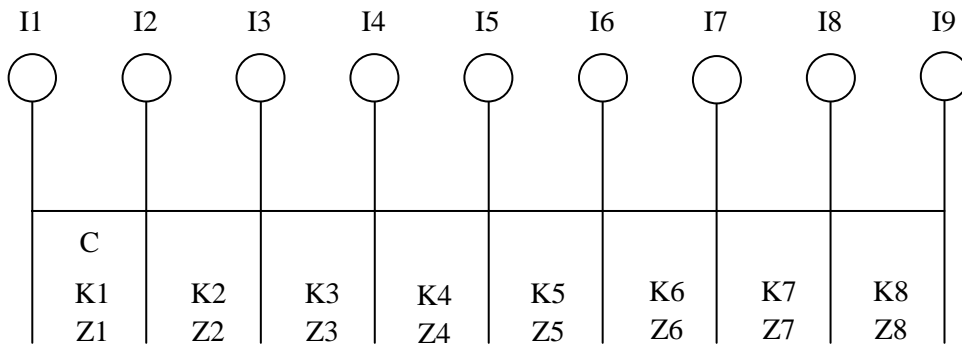

S6R2-M ELASTIC DATA

	Moment of inertia J kg.m ²	Damping coefficient Nm/rad/s	Spring const. x10 ⁷ Nm/rad	Tensile strength N/mm ²	Section modulus cm ³
I1	DAMPER	1.01	C=524.7	K1=0	Z1 =0.0
I2	PULLEY	1.192	—	K2=1.196	Z2 =373.7
I3	No.1 CRANK	0.810	—	K3=0.763	Z3 =373.7
I4	No.2 CRANK	0.480	—	K4=0.763	Z4 =373.7
I5	No.3 CRANK	0.800	—	K5=0.763	Z5 =373.7
I6	No.4 CRANK	0.800	—	K6=0.763	Z6 =373.7
I7	No.5 CRANK	0.480	—	K7=0.763	Z7 =373.7
I8	No.6 CRANK	0.810	—	K8=1.216	Z8 =373.7
I9	FLYWHEEL	5.59	—		

Hysteresis constant:177 No. of Cylinder: 6 Bore:170mm Stroke:220mm

Length of Con-Rod: 400mm Mass of Reciprocating Parts:12.870 kg

Firing order:1-5-3-6-2-4

Firing interval:0-120-240-360-480-600

APPLICATION : MARINE USE

The data is subject to change without notice.



MITSUBISHI HEAVY INDUSTRIES, LTD.
GENERAL MACHINERY & SPECIAL VEHICLE

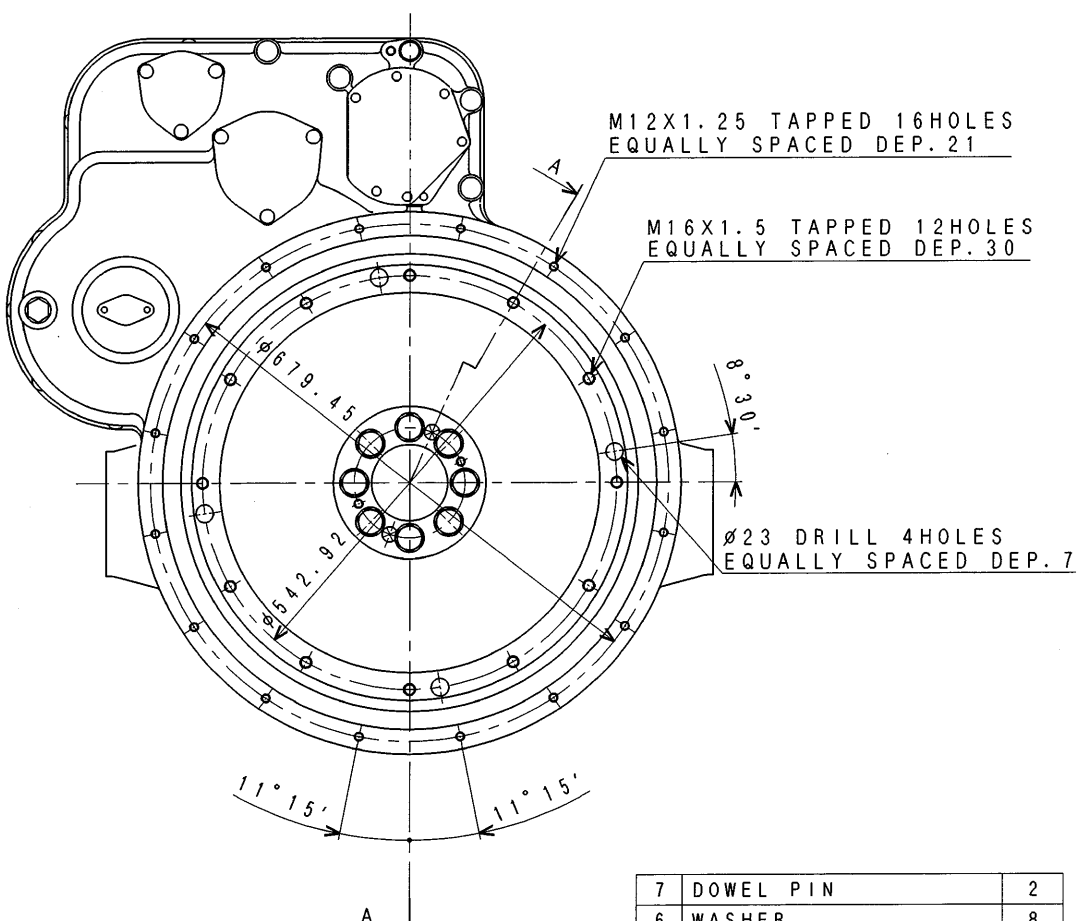
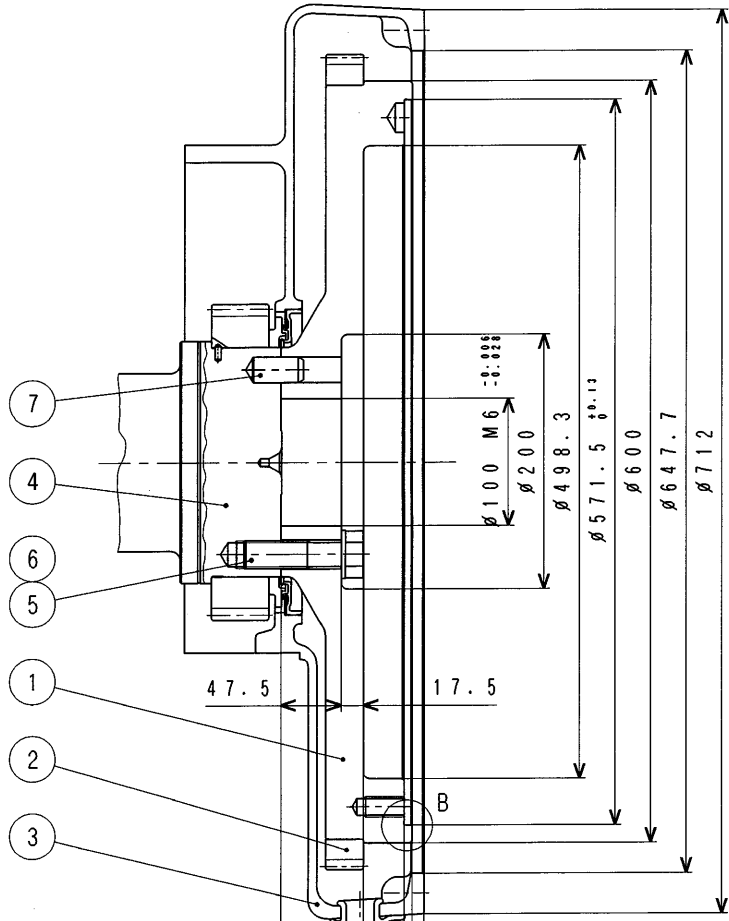

TO ϕ . ENGINE 757.5 112.5
 TO ϕ . ENGINE 870

SECTION A-A

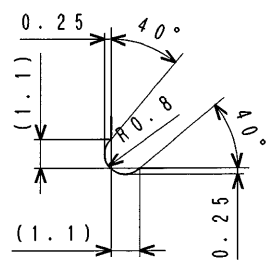

DETAIL B

MHI CONFIDENTIAL

7	DOWEL PIN	2
6	WASHER	8
5	FLYWHEEL BOLT	8
4	CRANK SHAFT	1
3	FLYWHEEL HOUSING	1
2	RING GEAR	1
1	FLYWHEEL	1
No.	PARTS NAME	Q'TY

(2) Flywheel SAE(J620d) Standard No. 18
 Note: (1) Flywheel Housing SAE(J617c) Standard No. 0

CHG	EO-NO	DATE	CHK	 3rd ANGLE PROJECTION 尺度 SCALE

FLYWHEEL & HOUSING DETAIL FOR S6R, S6R2
 三菱重工業株式会社 汎用機・特車事業本部
 GENERAL MACHINERY & SPECIAL VEHICLE HEADQUARTERS, MITSUBISHI HEAVY INDUSTRIES, LTD.
 図面番号 45R96-21000
 DRAWING No.

① 新図	サイズ	① 組立図	2 鋳造部品	3 板金溶接品	4 組立品
④ 旧引図	A 3	5 切削品	6 その他(購入品)		



FULL-CAD

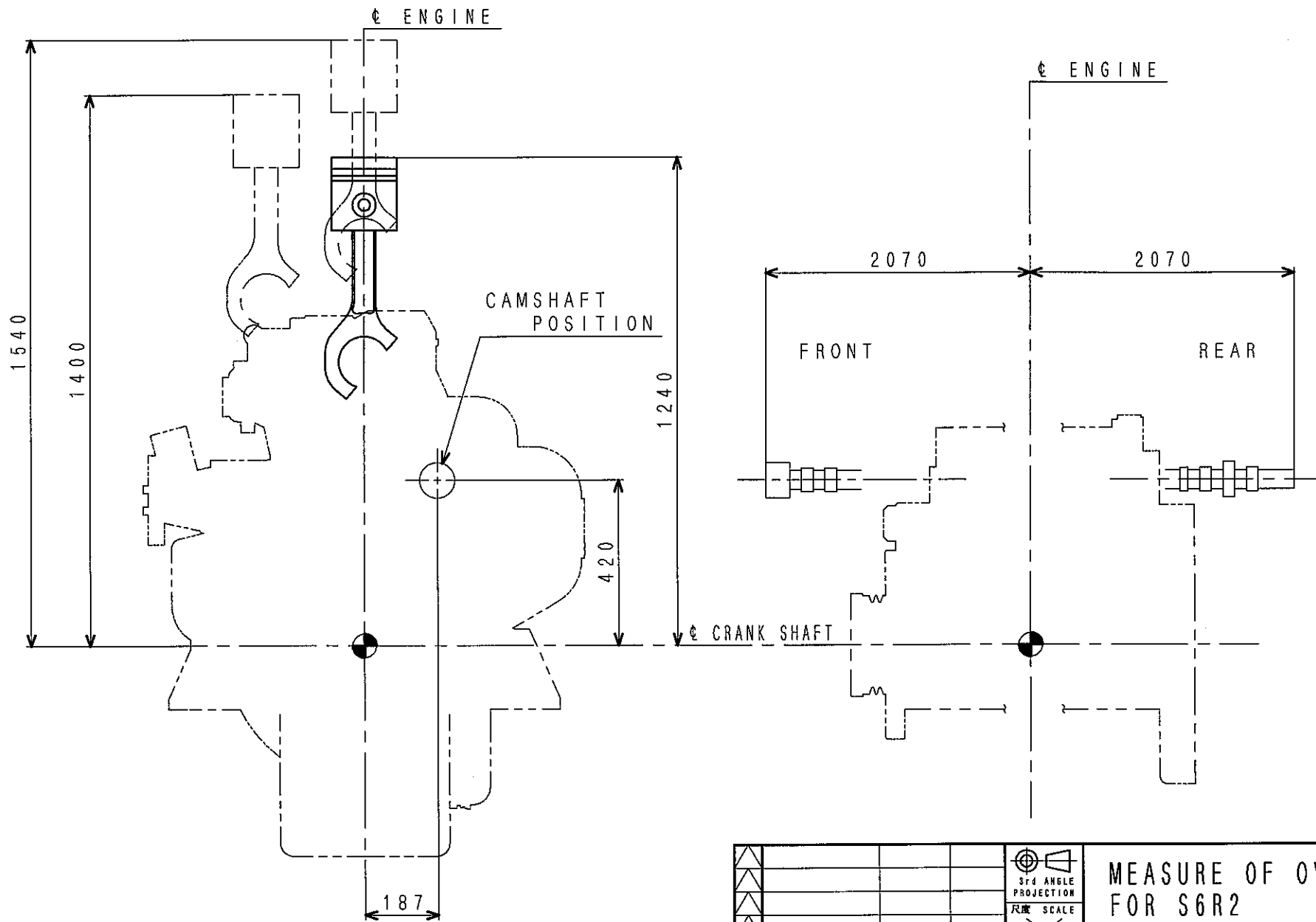

CHG	ED-NO	DATE	CHK	 3rd ANGLE PROJECTION 尺度 SCALE

MEASURE OF OVERHAUL FOR S6R2

三菱重工業株式会社 汎用機・特車事業本部
GENERAL MACHINERY & SPECIAL VEHICLE HEADQUARTERS, MITSUBISHI HEAVY INDUSTRIES, LTD.

図面番号
DRAWING No. 45R96-09001

S6R-090-82A

① 組立図 ② 分解標準品 ③ 板金油接品 ④ 組立品
⑤ 切削品 ⑥ その他(購入品)

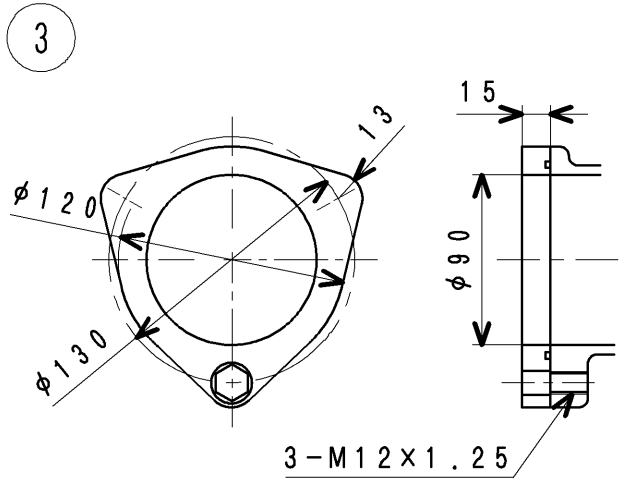

DETAIL OF FRESH WATER INLET

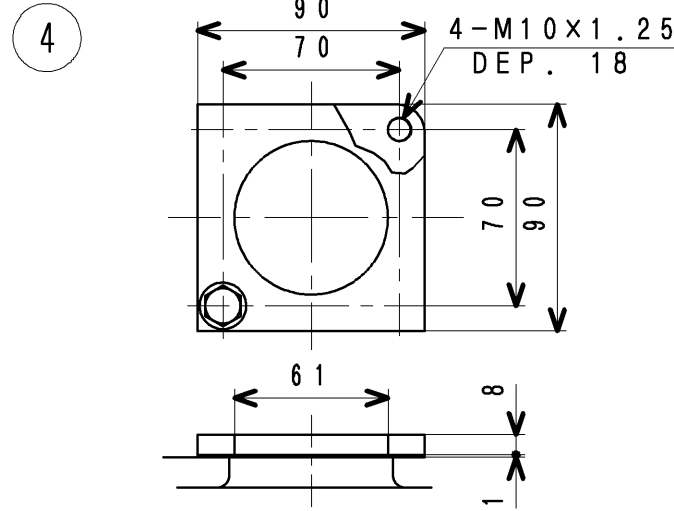

DETAIL OF FRESH WATER OUTLET

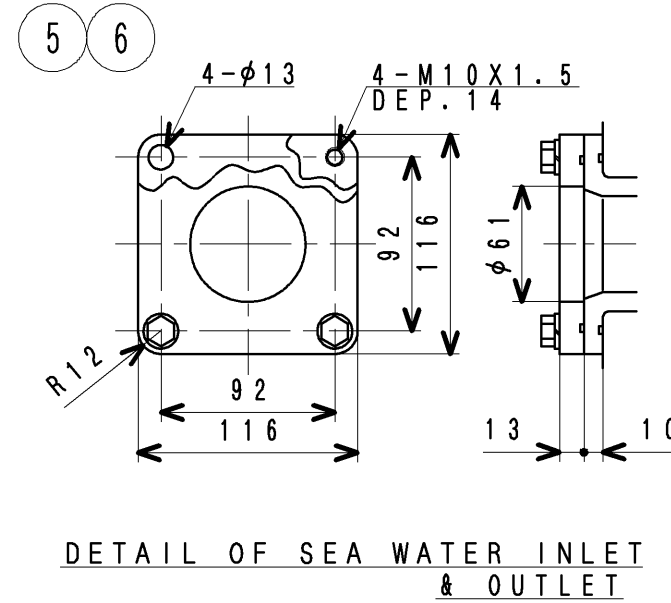

DETAIL OF SEA WATER INLET & OUTLET

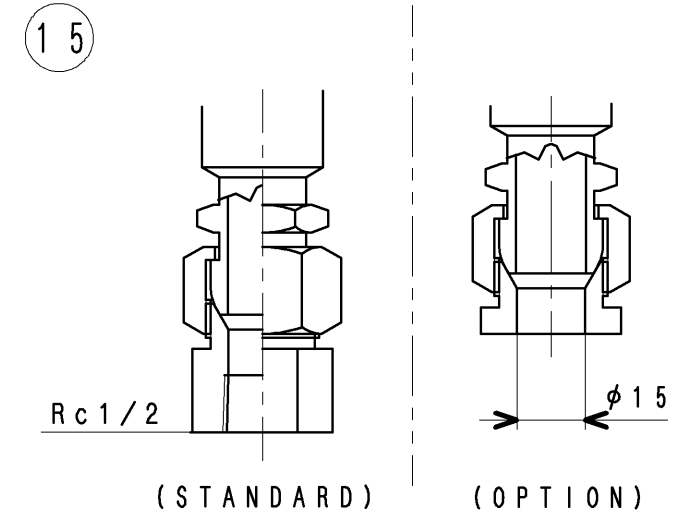

DETAIL OF FUEL PIPE JOINT

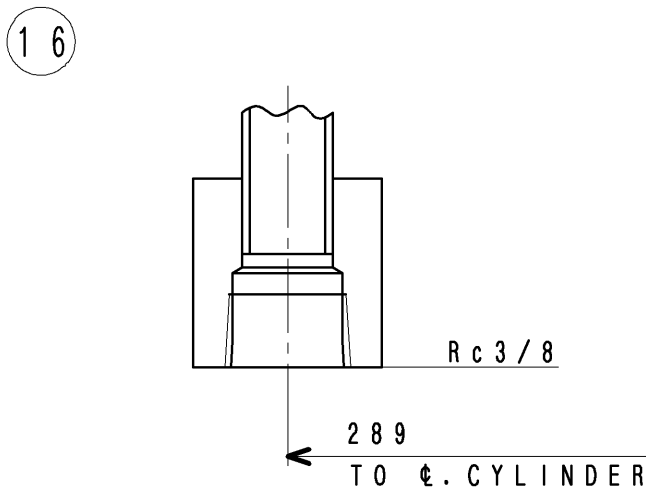

DETAIL OF FUEL RETURN PIPE ADAPTER

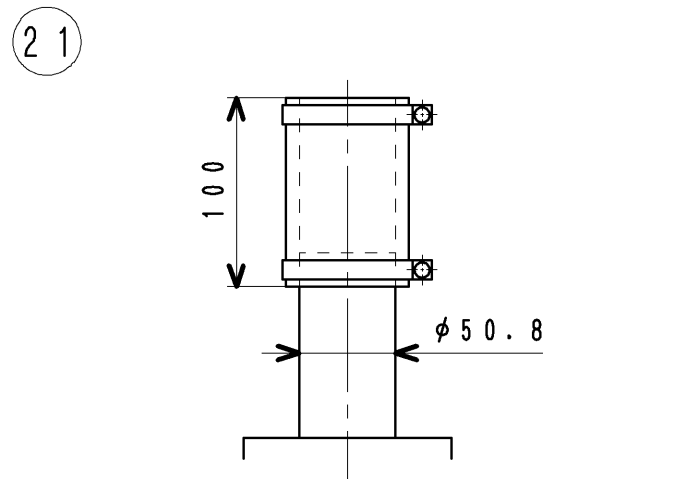

DETAIL OF MIST GAS OUTLET

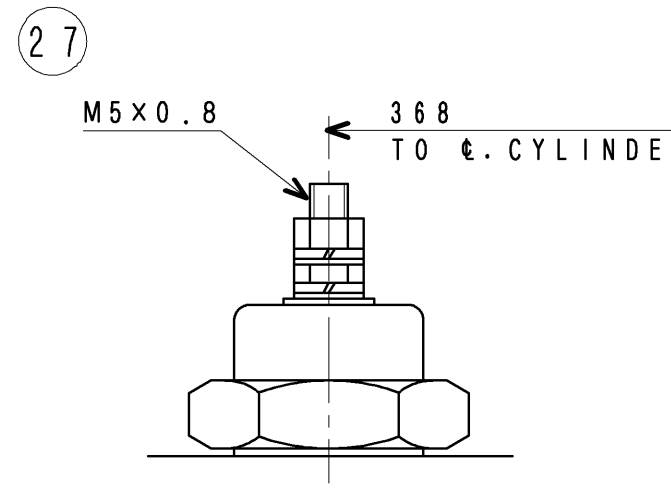

DETAIL OF FILTER ALARM

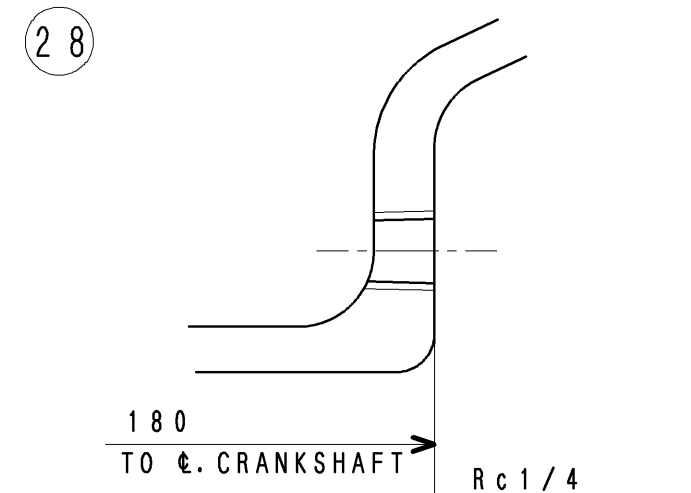

DETAIL OF AIR PRESS. GAUGE ADAPTER

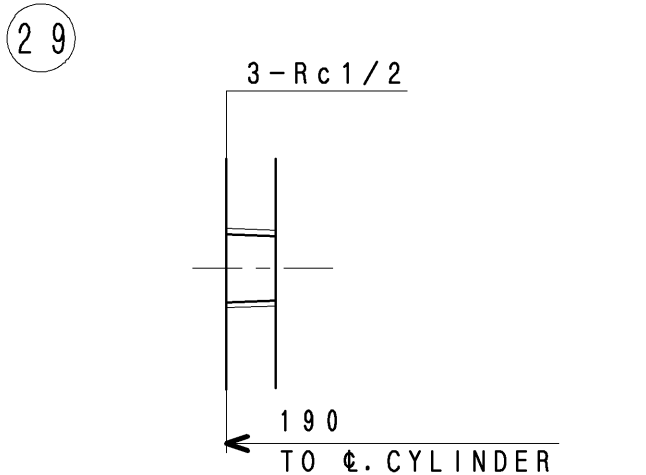

DETAIL OF THERMOMETER & THERMOSWITCH ADAPTER

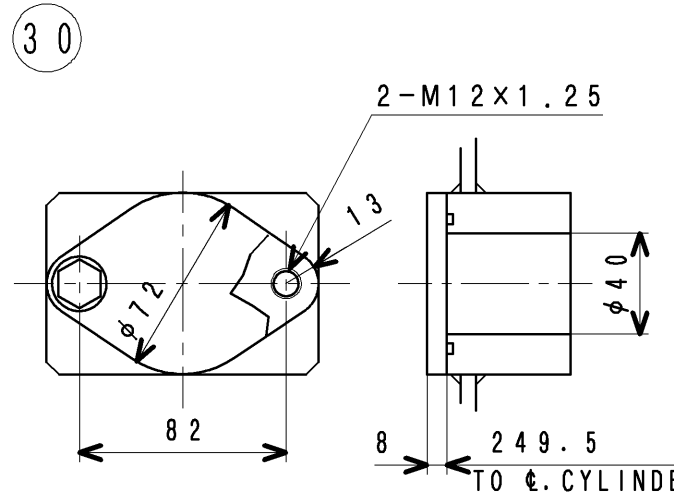

DETAIL OF OIL PAN ADAPTER (A)

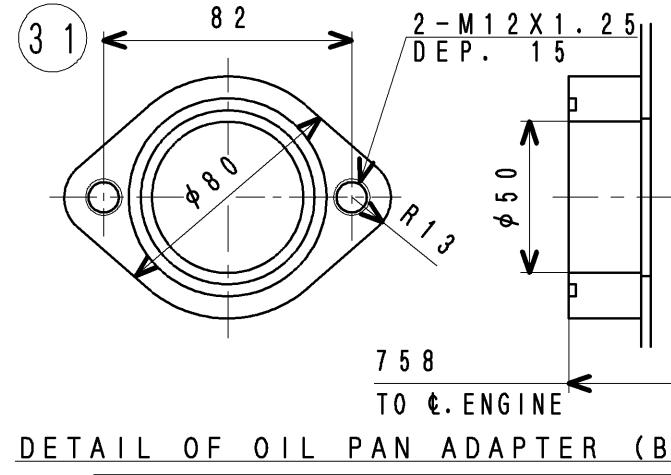

DETAIL OF OIL PAN ADAPTER (B)

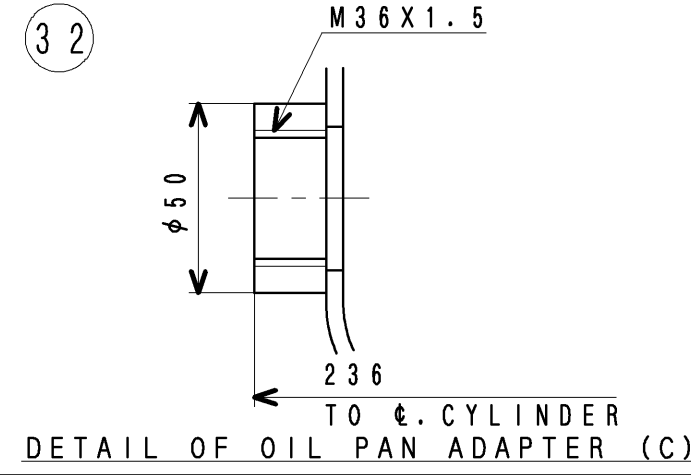

DETAIL OF OIL PAN ADAPTER (C)

MHI CONFIDENTIAL

MODEL
S6R-(T2)MPTK
S6R2-(T2)MPTK

CHG	ED-NO	DATE	CHK

3rd ANGLE PROJECTION
尺度 SCALE

S6R, S6R2 JOINT DETAIL

三菱重工業株式会社 汎用機・特車事業本部
MITSUBISHI HEAVY INDUSTRIES, LTD. GENERAL MACHINERY & SPECIAL VEHICLES.

図面番号 45R96-01005
DRAWING No.

③ 新図 サイズ A 3 ① 組立図 2 鋳鍛歯車品 3 板金溶接品 4 組立品
4 旧引図 5 切削品 6 その他(購入品)

出図
汎特
2013
7.5

M/C

33

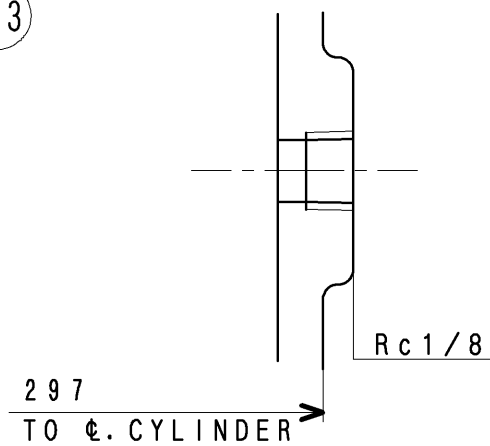

DETAIL OF OIL PRESS. GAUGE & PRESS. SWITCH ADAPTER

34

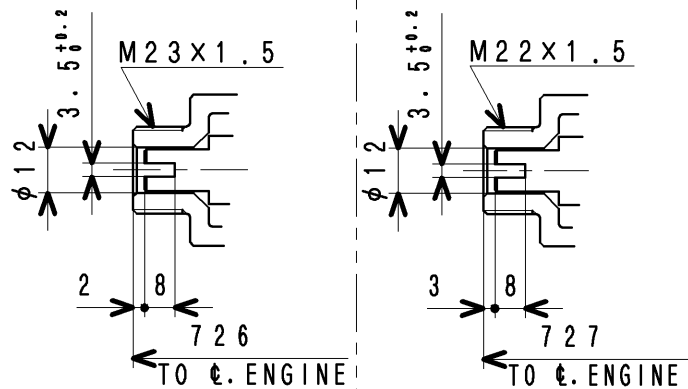

DETAIL OF TACHOMETER ADAPTER (STANDARD) (OPTION)

35

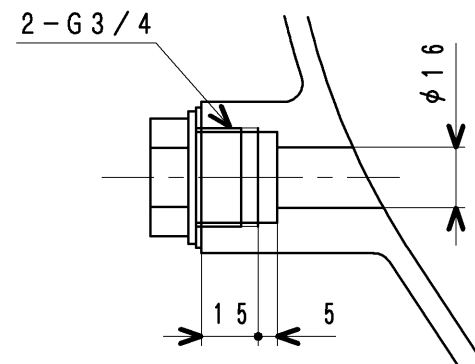

DETAIL OF THERMOMETER ADAPTER

36

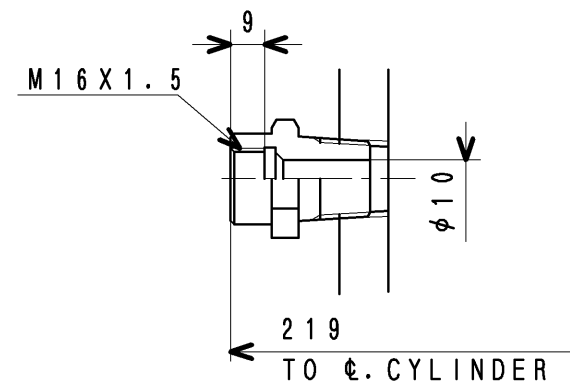

DETAIL OF THERMOMETER & THERMOSWITCH ADAPTER

MHI CONFIDENTIAL

CHG	ED-NO	DATE	CHK

3rd ANGLE PROJECTION
尺度 SCALE

S6R, S6R2 JOINT DETAIL

三菱重工業株式会社 汎用機・特車事業本部
MITSUBISHI HEAVY INDUSTRIES, LTD. GENERAL MACHINERY & SPECIAL VEHICLES.

図面番号 45R96-01005
DRAWING No. 2/2

③ 新図	サイズ A 3	① 組立図	2 鋳鍛歯車品	3 板金溶接品	4 組立品
4 旧引図			5 切削品	6 その他(購入品)	

出図
汎特
2013
7.5

M/C



**MITSUBISHI DIESEL ENGINE
TECHNICAL INFORMATION**

ITEM NO.

T0407-0015E Rev.2 (1/6)

DATE

Oct., 2011

Performance Curves of S6R2-T2MPTK

Performance Curves of S6R2-T2MPTK are enclosed herein. The data are test bench data and not a guaranteed performance.

THE INFORMATION HEREON IS THE PROPERTY OF MITSUBISHI HEAVY INDUSTRIES, LTD.
WITHOUT WRITTEN PERMISSION, ANY COPYING, TRANSMITTAL TO OTHERS, AND ANY USE
EXCEPT THAT FOR WHICH IT IS LOANED, IS PROHIBITED.

Revision	First Edition : Aug., 2011	Engine Engineering Department Engine System Designing Section		
	Rev.1 : Oct., 2011			
	Rev.2 : Mar., 2013	Approved by	Checked by	Drawn by

Rating: LIGHT DUTY-E3

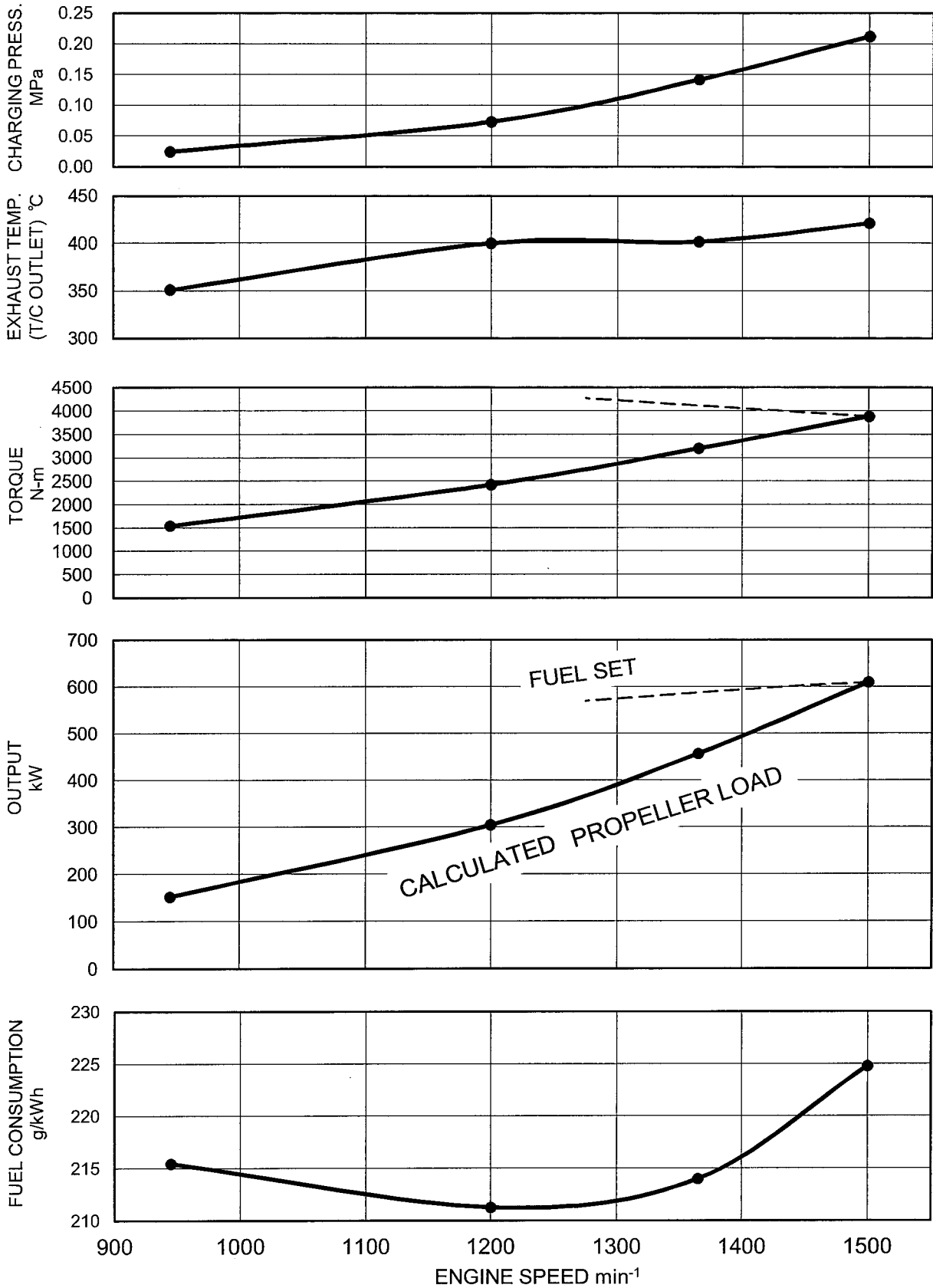

MHI CONFIDENTIAL

Fuel Consumption is based on ISO3046/1 with +5% tolerance at rated power.
The specifications are subject to change without notice.

APPLICATION : MARINE PROPULSION

Pub. No.T0407-0015E Rev.2 2/6

Rating: MEDIUM DUTY-E3

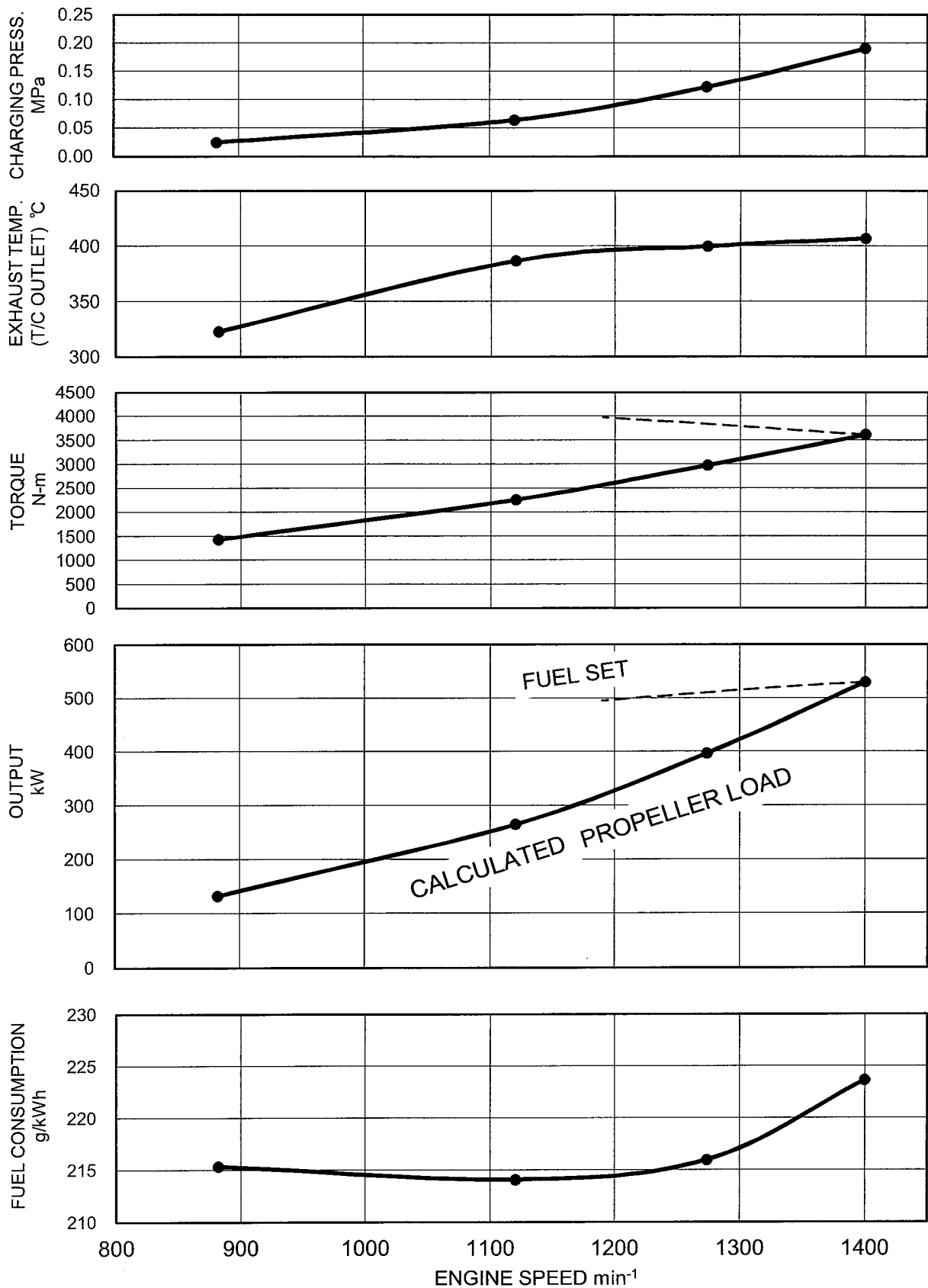

MHI CONFIDENTIAL

Fuel Consumption is based on ISO3046/1 with +5% tolerance at rated power.
The specifications are subject to change without notice.

APPLICATION : MARINE PROPULSION

Pub. No.T0407-0015E Rev.2 3/6

Rating: HEAVY DUTY-E3

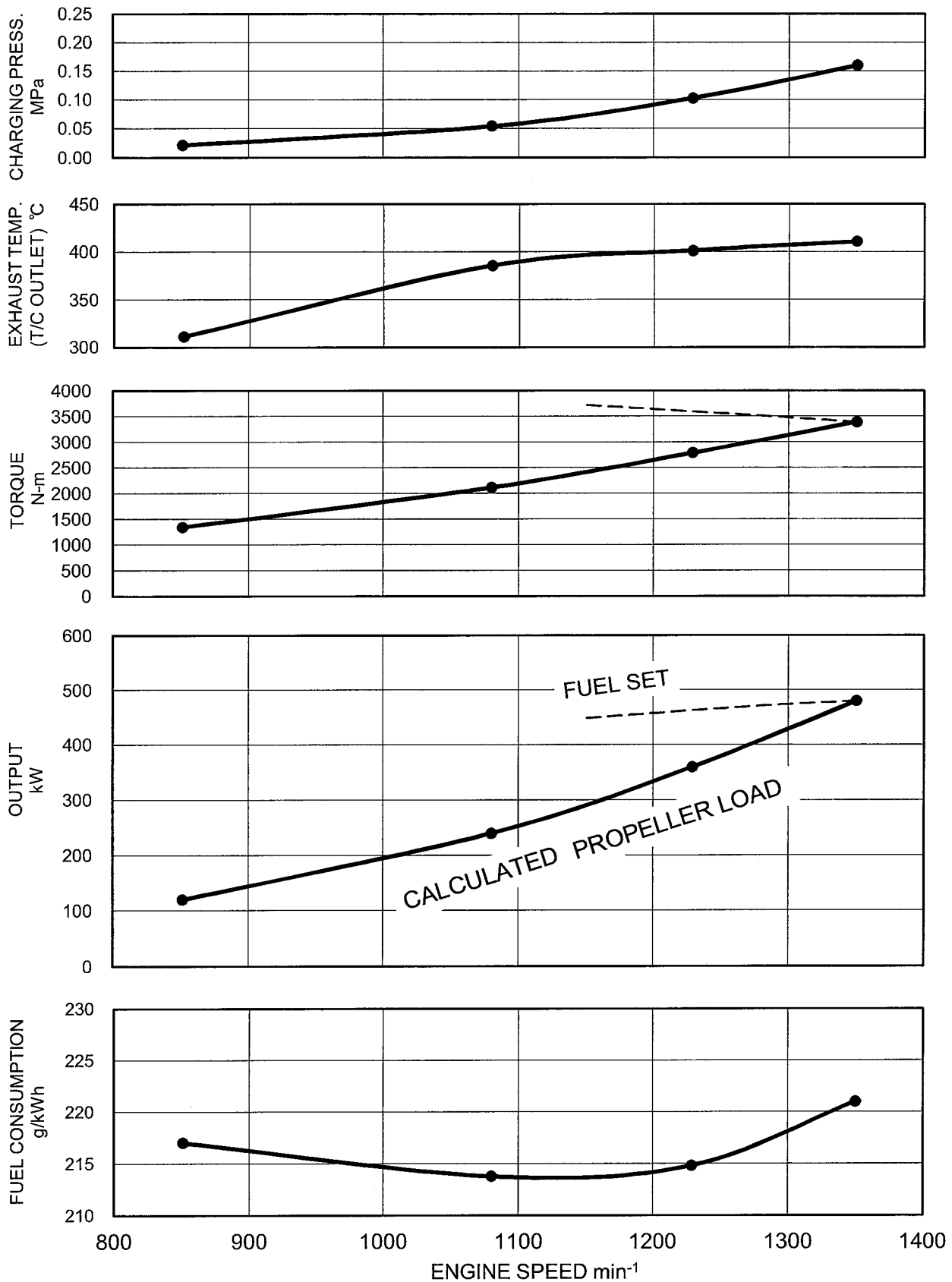

MHI CONFIDENTIAL

Fuel Consumption is based on ISO3046/1 with +5% tolerance at rated power.
The specifications are subject to change without notice.

APPLICATION : MARINE PROPULSION

Pub. No.T0407-0015E Rev.2 4/6

Engine speed: 1200min⁻¹

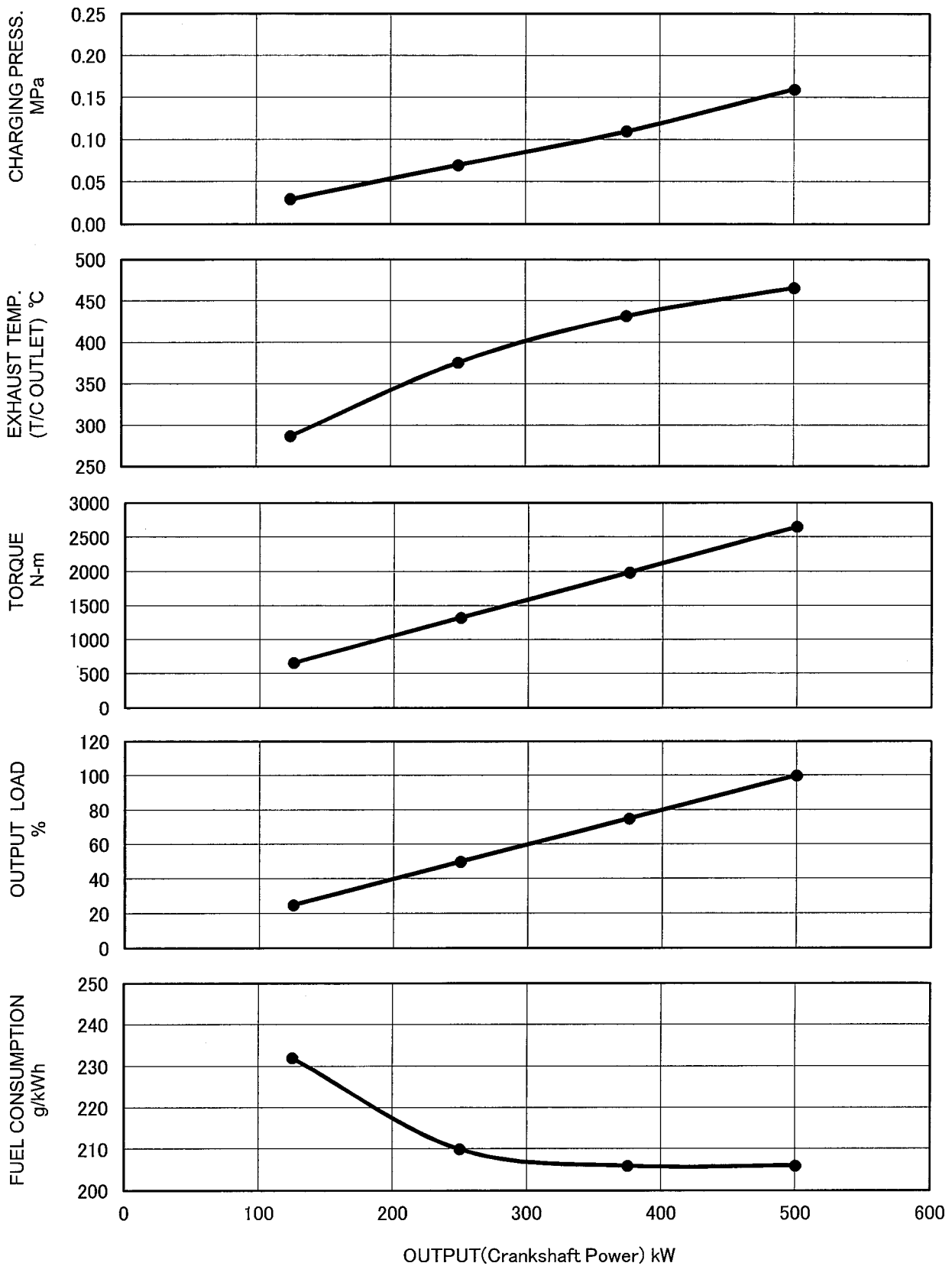

MHI CONFIDENTIAL

Fuel Consumption is based on ISO3046/1 with +5% tolerance at rated power.
The specifications are subject to change without notice.

APPLICATION : GENERATOR

Pub. No.T0407-0015E Rev.2 5/6

Engine speed: 1500min⁻¹

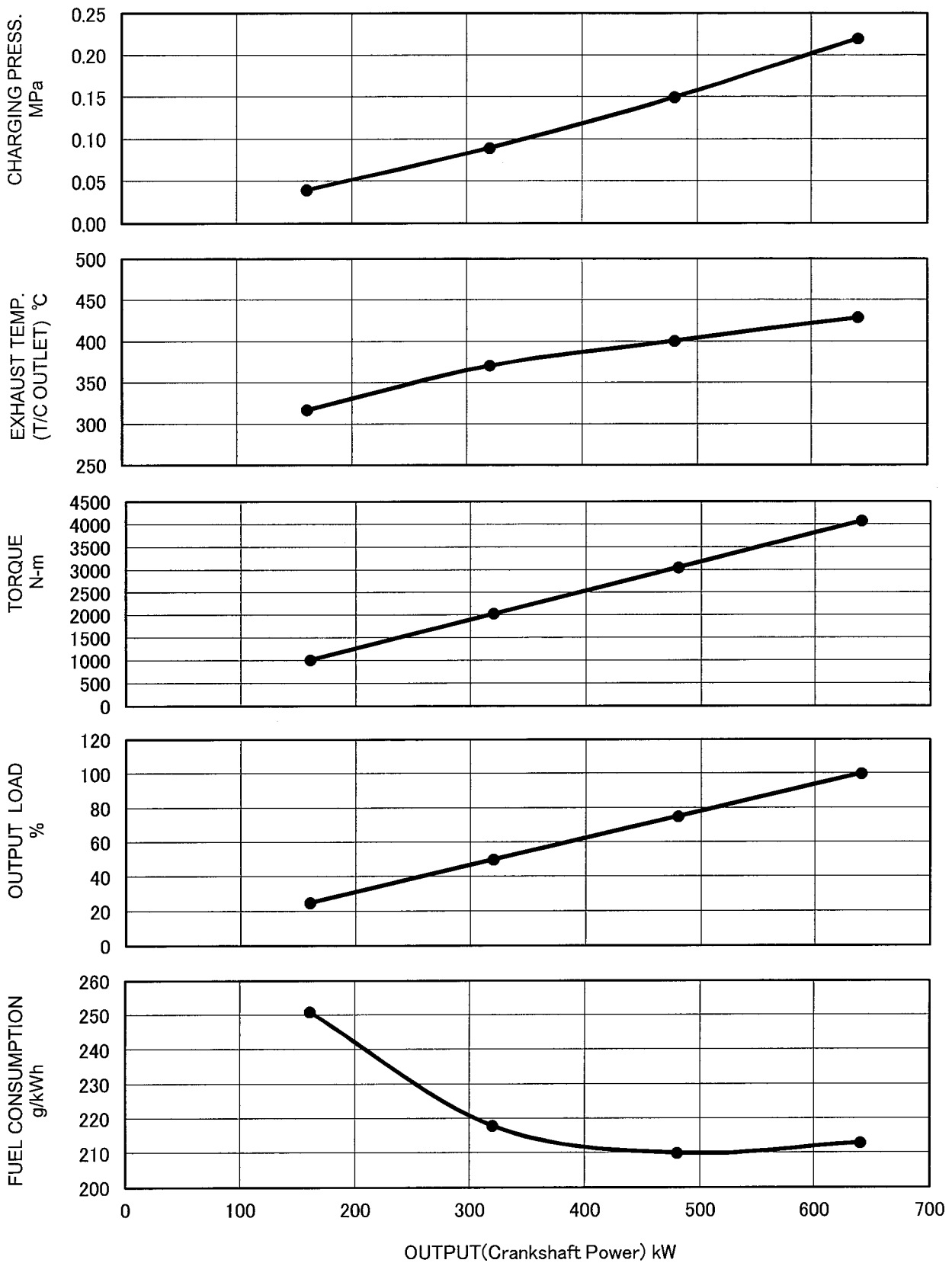

MHI CONFIDENTIAL

Consumption is based on ISO3046/1 with +5% tolerance at rated power.
The specifications are subject to change without notice.

APPLICATION : GENERATOR

Pub. No.T0407-0015E Rev.2 6/6