



## **mitsubishi S6R2-T2MPTK-3**

Click on the headlines below to get redirected to the respective sections in this document.

[Technical data](#)  
[Elastic drawing](#)  
[Flywheel & housing drawing](#)  
[Measure of overhaul](#)  
[Connection details](#)  
[Performance curves](#)



**MITSUBISHI**  
DIESEL ENGINE

Item no.	M0209-0012E
Date	April 2013

Specification sheet of S6R2-T2MPTK marine diesel engine

Specification sheet of:  
- S6R2-T2MPTK (in compliance with IMO MARPOL 73/78, Annex VI, Regulation 13, Tier 2)

Revision	0	First edition: March 2012	Technology Department Engine Division		
	1	April 2013			
			Approved by	Checked by	Drawn by

## GENERAL ENGINE DATA

Type	-----	4-Cycle, Water Cooled	
Aspiration	-----	Turbo-Charged, Inter Cooler (Raw water to Cooler)	
Cylinder Arrangement	-----	Inline	
No. of Cylinders	-----	6	
Bore mm(in.)	-----	170	(6.69)
Stroke mm(in.)	-----	220	(8.66)
Displacement Liter(in. <sup>3</sup> )	-----	29.96	(1828)
Compression Ratio	-----	14.0 : 1	
Dry Weight - Engine only - kg(lb)	-----	2960	(6527)
Wet Weight - Engine only - kg(lb)	-----	3150	(6946)

## PERFORMANCE DATA

Steady State Speed Stability Band at any Constant Load(Generator Use)			
Hydraulic (std.) or Electric Governor - %	-----	±0.25 or better	
Idling Speed -rpm	-----	600~650	
Maximum Overspeed Capacity - rpm	-----	1750	
Moment of Inertia of Rotating Components J - kg · m <sup>2</sup> (lb · ft <sup>2</sup> )	-----	11.96	(1135)
(Includes 18 inch Flywheel)			
Cyclic Speed Variation with Flywheel at	1500rpm	-----	1/116
	1200rpm	-----	1/76

## ENGINE MOUNTING

Maximum Bending Moment at Rear Face of Flywheel Housing - N · m (lb · ft)	-----	1961	(1447)
---	-------	------	--------

## AIR INLET SYSTEM

Maximum Intake Air Restriction (Includes piping)- kPa (in. H <sub>2</sub> O)	-----	3.92	(15.7)
Maximum Allowable Intake Air Temperature- °C (°F)	-----	45	(113)

## EXHAUST SYSTEM

Maximum Allowable Back Pressure - kPa (in. H <sub>2</sub> O)	-----	4.41	(17.7)
--	-------	------	--------

## LUBRICATION SYSTEM

Oil Pressure	at Idle - MPa (psi)	-----	0.2~0.3	(29~43)
	at Rate Speed - MPa (psi)	-----	0.5~0.64	(71~93)
Maximum Oil Temperature- °C (°F)	-----	110	(230)	
Lub Oil Standard Thermostat (Modulating) Range- °C (°F)	-----	82~95	(180~203)	
Oil Capacity of Marine Pan	High - liter (U.S.gal)	-----	140	(37.0)
	Low - liter (U.S.gal)	-----	110	(29.1)
Total System Capacity (Includes Oil Filter) - liter (U.S.gal)	-----	160	(42.3)	
Maximum Installation Angle	Front Up	-----	8°	
	Front Down	-----	8°	
	Maximum Instantaneous Operating Angle	Front Up	-----	25°
(Engine Level)	Front Down	-----	15°	
	Side to Side	-----	22.5°	

## COOLING SYSTEM

## Jacket water system

Cooling system: Closed fresh water type High Temperature (HT) system with treated water/glycol mixture			
Coolant Capacity of Jacket Water System (Engine only) - liter (U.S.gal)	-----	55	(14.5)
Maximum External Friction Head at Engine Outlet-MPa(PSI)	-----	0.034	(5.0)
Jacket Water Standard Thermostat (Modulating) Range- °C (°F)	-----	71~85	(160~185)
Maximum Allowable Coolant Temperature at Engine Outlet- °C (°F)	-----	95	(203)
Recommended Coolant Temperature at Engine outlet- °C (°F)	-----	80	(176)

## Charge air cooler cooling system

Cooling system: Direct sea water or Closed fresh water type Low Temperature (LT) system with treated water/glycol mixture				
Coolant Capacity of Charge Air Cooler (Engine only) - liter (U.S.gal)	-----	7	(1.8)	
Maximum External Friction Head at Intercooler Outlet-MPa(PSI)	-----	0.035	(5.1)	
Maximum Coolant Temperature at Intercooler Inlet	-----	see page 4/4		
Minimum Coolant Expansion Space -% of System Capacity	-----	10		
Recommended Static Head of Coolant above Crankshaft Center - m(ft)	MAX.	-----	10	(32.8)
	MIN.	-----	7	(23.0)

The specifications are subject to change without prior notice.

## FUEL SYSTEM

Fuel Injection Pump	-----	Mitsubishi PS6 Type x 1
Maximum Suction Head of Feed Pump - kPa (in. Hg)	-----	14.7 (4.3)
Maximum Level of Fuel Tank - m	Continuous Use -----	5.0
	Stand-by Use -----	2.0
Minimum Fuel Oil Supply Pipe Inner Diameter - mm(in.)	-----	16 (0.63)
Minimum Fuel Oil Leak Pipe Inner Diameter - mm(in.)	-----	16 (0.63)

## STARTING SYSTEM

Battery Charging Alternator - V-Ah	-----	24-35
Starting Motor Capacity - V -kW	-----	24-7.5
Maximum Allowable Resistance of Cranking Circuit - m Ω	-----	2.5
Recommended Minimum Battery Capacity		
At 5°C (41°F) and above - Ah	-----	200
Below 5°C (41°F) through -5°C (23°F)	-----	500
Cranking Ampere of Starter at 5°C (41°F) / -5°C (23°F)		
Static Ampere -A		370 / 500
Momentary Ampere -A		700 / 960

## ACCESSORY EQUIPMENT

Air Cleaner	Silencer Type
Exhaust Manifold	Water Cooled
Turbocharger	Air cooled
Air Cooler	Raw Water Cooled
Breather	Conduction Type
Governor	Hydraulic PSG Type or electronic (optional)
Fuel Injection Pump	
Fuel Feed Pump	
Fuel Injection Pipe	Double walled Type
Fuel Injection Nozzle	
Fuel Filter	Paper Element Type
Lubricating Oil Pump	
Lubricating Oil Cooler	
Lubricating Oil Filter(Full-Flow)	Paper Element Type
Lubricating Oil Filter(By-Pass Flow)	Paper Element Type
Oil Pan	Large Capacity,steel
Lubricating Oil Thermostat	
Cooling Water Pump (HT)	
Cooling Water Thermostat (HT)	
Starter	Earth Floated Type
Alternator	Earth Floated Type
Stop Solenoid	DC24V-15A
Engine Support	Marine Type
Accessory Drive	Front Drive Pulley

The specifications are subject to change without prior notice.

ENGINE RATING<sup>1</sup>

All data represent net performance according to ISO 3046 with standard accessories such as fuel injection pump, water pump, L.O. pump and charging alternator under the condition of 100 kPa (750 mmHg) barometric pressure, 298 °K (25 °C) ambient temperature and 30% relative humidity

ITEM Engine Model	UNIT	propulsion use		auxiliary generator		
		-T2MPTK-3		-T2MPTK-5	-T2MPTK-9	
Rating		Heavy Duty		50 Hz	60 Hz	
Rated engine speed	rpm	1350		1500	1200	
Emission Regulation (Test cycle)	IMO Tier 2	E2 (CPP) / E3 (FPP)		D2	D2	
No. of Cylinders		6				
Bore	mm (in.)	170 (6.69)				
Stroke	mm (in.)	220 (8.66)				
Displacement	liter (in. <sup>3</sup> )	29.96 (1828.27)				
Rated output <sup>1</sup>	kW (HP)	480 (643)		640 (858)	500 (670)	
Brake Mean Effective Pressure	MPa (psi)	1.42 (206)		1.71 (248)	1.67 (242)	
Mean Piston Speed	m/s (ft/min)	9.9 (1949)		11.0 (2166)	8.8 (1732)	
Maximum Regenerative Power	kW	52		60	44	
Absorption Capacity	(HP)	(70)		(80)	(59)	
Intake Air Flow	m <sup>3</sup> /min (CFM)	43 (1518)		57 (2012)	43 (1518)	
Exhaust Gas Flow	m <sup>3</sup> /min (CFM)	113 (3990)		152 (5367)	113 (3990)	
Coolant Flow	liter/min (U.S. GPM)	730 (193)		820 (217)	650 (172)	
Coolant(Jacket water) Pressure (water pump outlet)	MPa (psi)	0.14 (21)		0.17 (25)	0.11 (16)	
Minimum Coolant Flow to Inter Cooler (Max. Flow: 469L/min)	liter/min (U.S. GPM)	150 (40)		150 (40)	150 (40)	
Oil Flow	liter/min (U.S. GPM)	260 (69)		290 (77)	230 (61)	
Radiated Heat to Ambient	kJ/hr (BTU/min)	89444 (1413)	89866 (1420)	120478 (1903)	90123 (1424)	
Heat Rejection to Coolant (include water cooled manifold)	kJ/hr (BTU/min)	1073331 (16956)	1078394 (17036)	1445732 (22839)	1081472 (17085)	
Heat Rejection to Inter Cooler (PTK Version)	kJ/hr (BTU/min)	402499 (6359)	404398 (6389)	542149 (8565)	405552 (6407)	
Heat Rejection to Exhaust	kJ/hr (BTU/min)	1180455 (18649)	1194167 (18865)	1611758 (25462)	1130009 (17852)	
Cooling system	Direct Sea Water Cooling Max. sea water temp. at intercooler inlet	°C	Max. 32°C			
	Intermediate Fresh Water Cooling Max. fresh water temp. at intercooler inlet	°C	Max. 38°C (When sea water temp. 32°C)			
	Radiator Cooling Max. coolant temp. at intercooler inlet	°C	N/A		Max. 45°C (When Air Temp. 25°C)	
Noise Level (1 m height & distance) (excludes, Intake,Exhaust)	dB(A)	-	-	-	-	
Maximum No Load Governed Speed	rpm	1451	1451	1575	1260	

<sup>1</sup> the rated output is available up to IACS ambient reference conditions without derating



**MITSUBISHI DIESEL ENGINE  
TECHNICAL INFORMATION**

ITEM NO.

T0307-0027E (1/2)

DATE

April, 2007

Elastic data of S6R2-M Engine

Elastic data of S6R2-M Engine are enclosed herein.

Revision	First Edition : April, 2007 (Refer to MTD00-0019)	Engine Engineering Department Large Engine Design Section		
		Approved by	Checked by	Drawn by

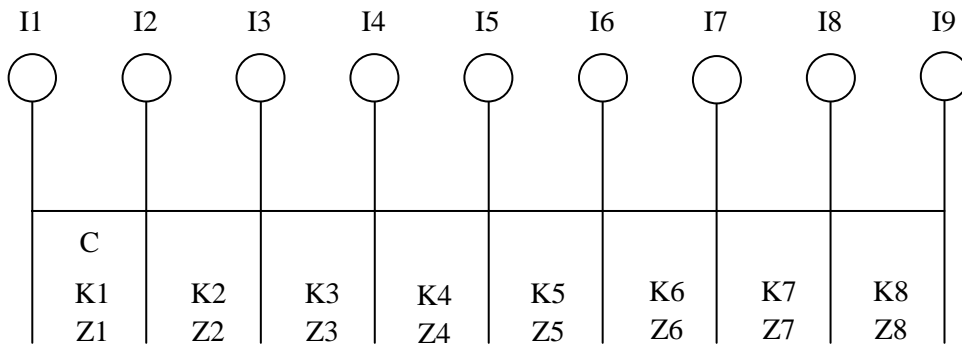

**S6R2-M ELASTIC DATA**

	Moment of inertia J kg.m <sup>2</sup>	Damping coefficient Nm/rad/s	Spring const. x10 <sup>7</sup> Nm/rad	Tensile strength N/mm <sup>2</sup>	Section modulus cm <sup>3</sup>
I1	DAMPER	1.01	C=524.7	K1=0	Z1 =0.0
I2	PULLEY	1.192	—	K2=1.196	Z2 =373.7
I3	No.1 CRANK	0.810	—	K3=0.763	Z3 =373.7
I4	No.2 CRANK	0.480	—	K4=0.763	Z4 =373.7
I5	No.3 CRANK	0.800	—	K5=0.763	Z5 =373.7
I6	No.4 CRANK	0.800	—	K6=0.763	Z6 =373.7
I7	No.5 CRANK	0.480	—	K7=0.763	Z7 =373.7
I8	No.6 CRANK	0.810	—	K8=1.216	Z8 =373.7
I9	FLYWHEEL	5.59	—		

Hysteresis constant:177 No. of Cylinder: 6 Bore:170mm Stroke:220mm

Length of Con-Rod: 400mm Mass of Reciprocating Parts:12.870 kg

Firing order:1-5-3-6-2-4

Firing interval:0-120-240-360-480-600

APPLICATION : MARINE USE

The data is subject to change without notice.



**MITSUBISHI HEAVY INDUSTRIES, LTD.**  
GENERAL MACHINERY & SPECIAL VEHICLE

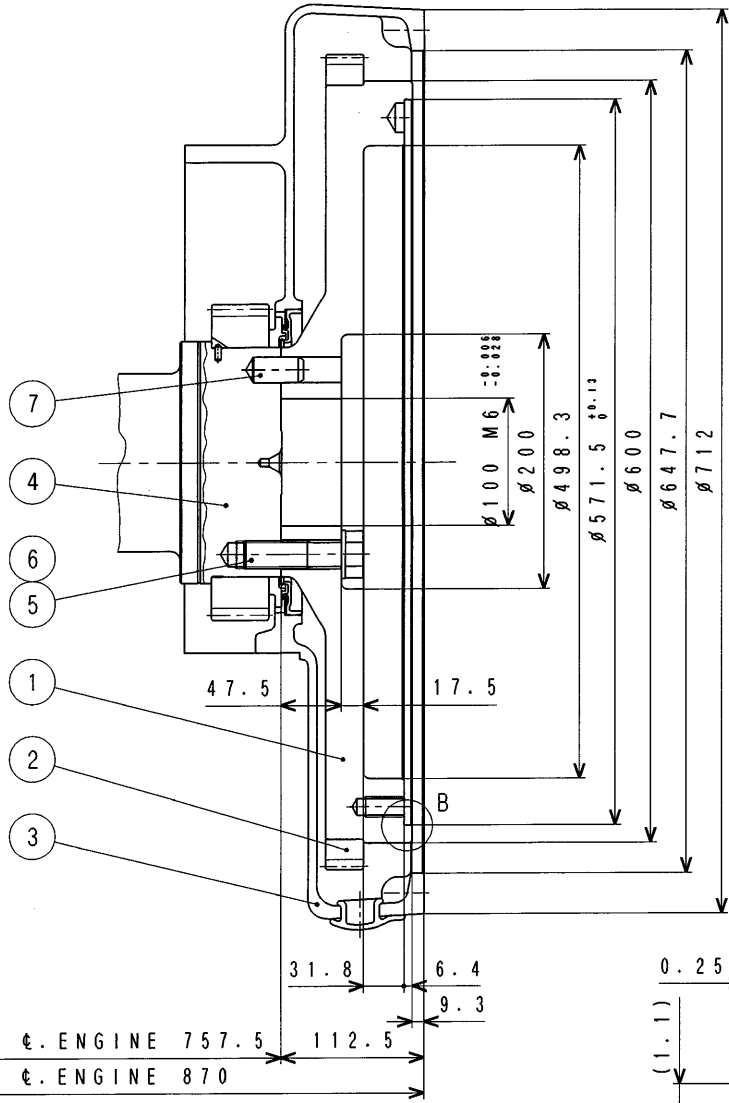

SECTION A-A

TO  $\phi$ . ENGINE 757.5  
TO  $\phi$ . ENGINE 870

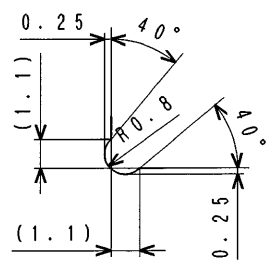

DETAIL B

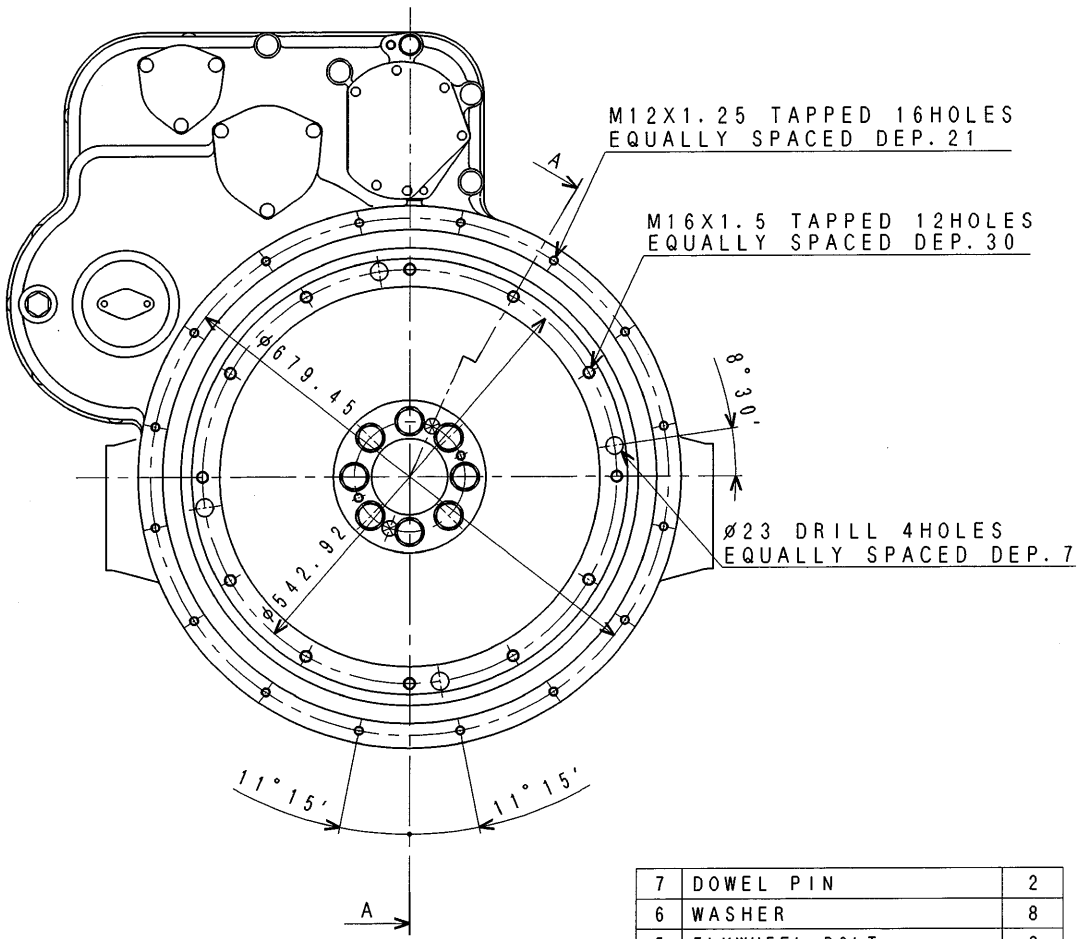

M12X1.25 TAPPED 16HOLES  
EQUALLY SPACED DEP. 21

M16X1.5 TAPPED 12HOLES  
EQUALLY SPACED DEP. 30

$\phi 23$  DRILL 4HOLES  
EQUALLY SPACED DEP. 7

MHI CONFIDENTIAL

7	DOWEL PIN	2
6	WASHER	8
5	FLYWHEEL BOLT	8
4	CRANK SHAFT	1
3	FLYWHEEL HOUSING	1
2	RING GEAR	1
1	FLYWHEEL	1
No.	PARTS NAME	Q'TY

出図  
MHI  
汎特  
2002  
6.28

FULL-CAD

(2) Flywheel SAE(J620d) Standard No. 18  
Note: (1) Flywheel Housing SAE(J617c) Standard No. 0

CHG	EO-NO	DATE	CHK	3rd ANGLE PROJECTION 尺度 SCALE

FLYWHEEL & HOUSING DETAIL  
FOR S6R, S6R2

三菱重工業株式会社 汎用機・特車事業本部  
GENERAL MACHINERY & SPECIAL VEHICLE HEADQUARTERS, MITSUBISHI HEAVY INDUSTRIES, LTD.

図面番号 45R96-21000  
DRAWING No.

① 新図 ② 組立図 ③ 鋳造部品 ④ 板金溶接品 ⑤ 組立品  
④ 旧引図 ⑤ A 3 ⑥ 切削品 ⑦ その他(購入品)



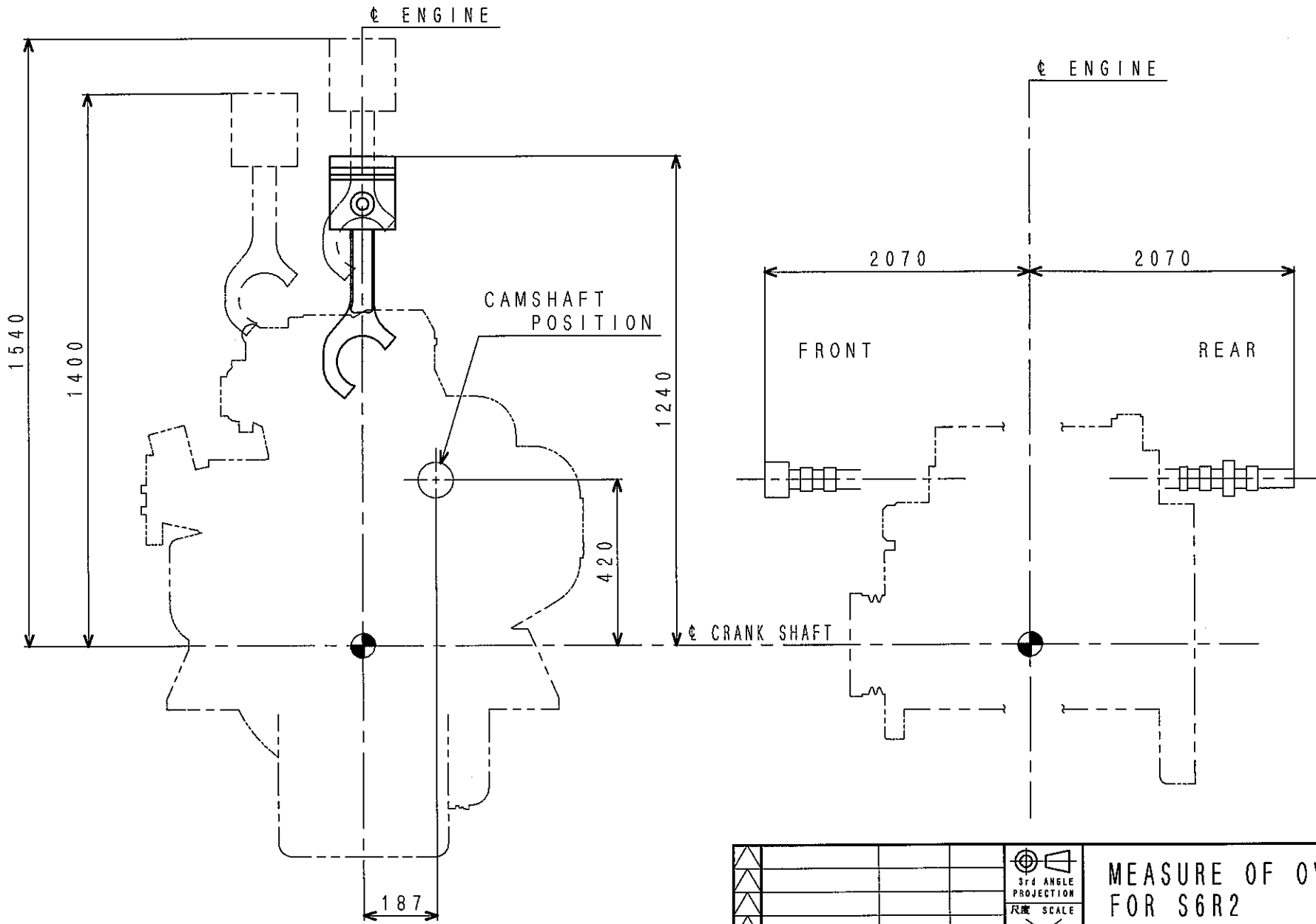

CHG	ED-NO	DATE	CHK	 3rd ANGLE PROJECTION 尺度 SCALE

### MEASURE OF OVERHAUL FOR S6R2

三菱重工業株式会社 汎用機・特車事業本部  
 GENERAL MACHINERY & SPECIAL VEHICLE HEADQUARTERS, MITSUBISHI HEAVY INDUSTRIES, LTD.

図面番号 DRAWING No. 45R96-09001

S6R-090-82A

- ① 組立図
- ② 分解標準品
- ③ 板金油接品
- ④ 組立品
- ⑤ 切削品
- ⑥ その他(購入品)

FULL-CAD

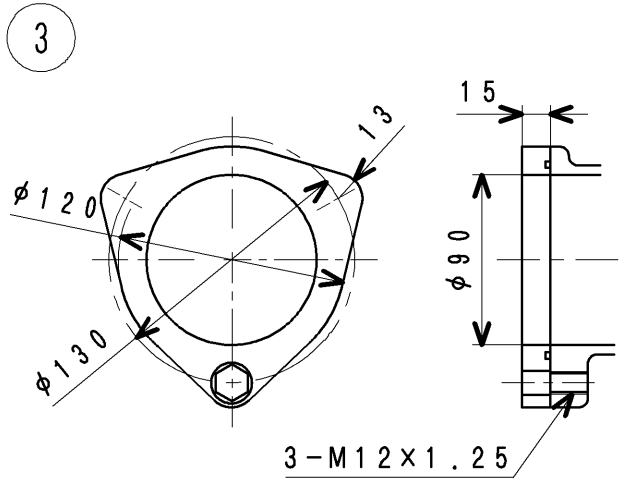

DETAIL OF FRESH WATER INLET

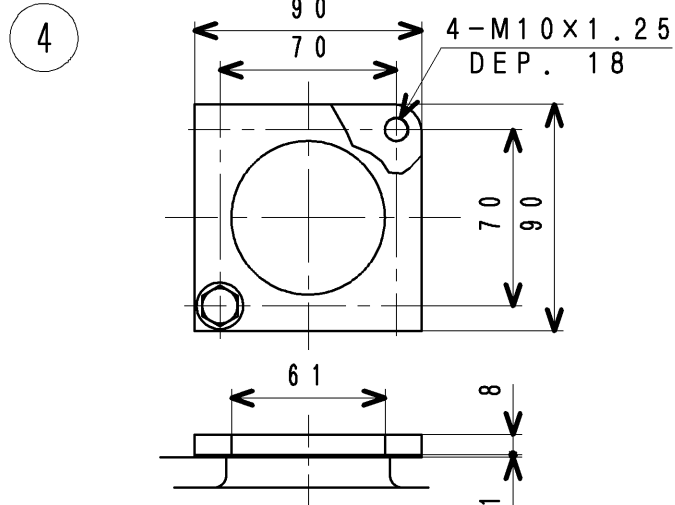

DETAIL OF FRESH WATER OUTLET

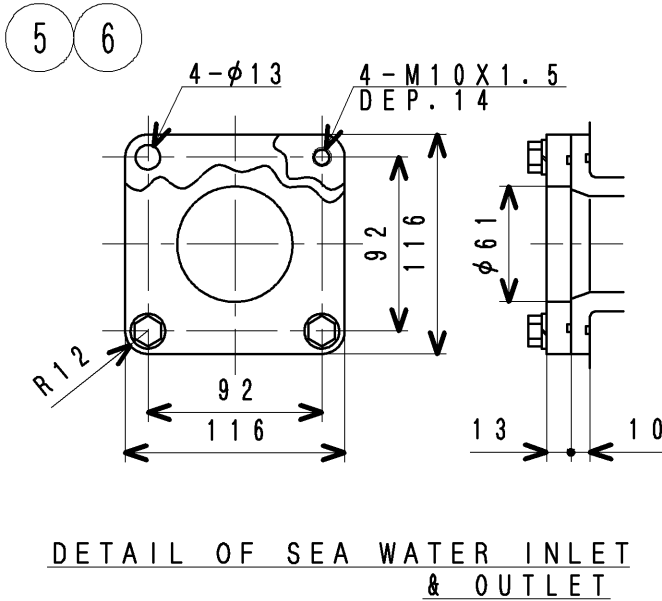

DETAIL OF SEA WATER INLET & OUTLET

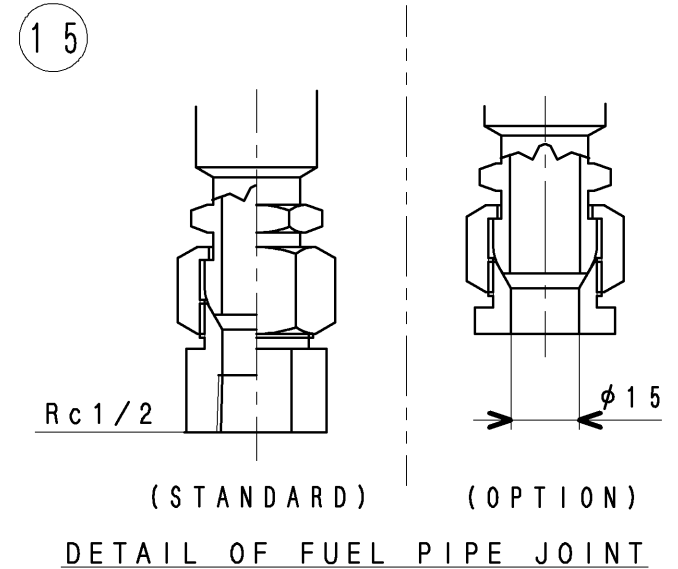

DETAIL OF FUEL PIPE JOINT

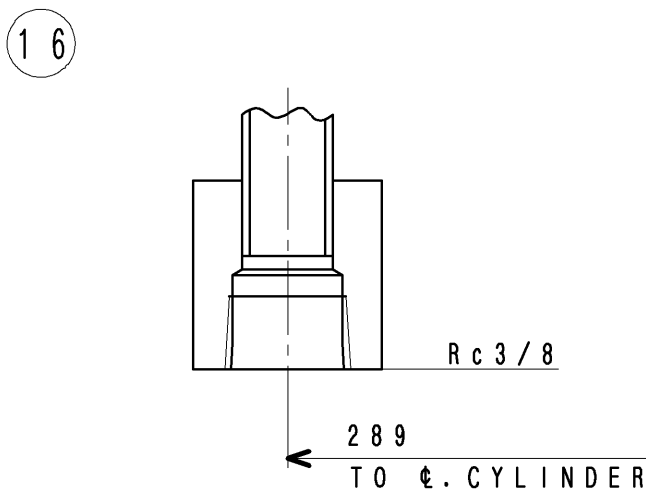

DETAIL OF FUEL RETURN PIPE ADAPTER

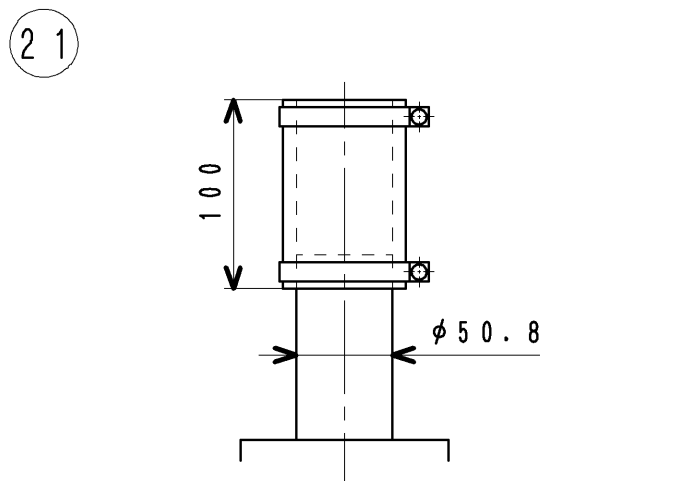

DETAIL OF MIST GAS OUTLET

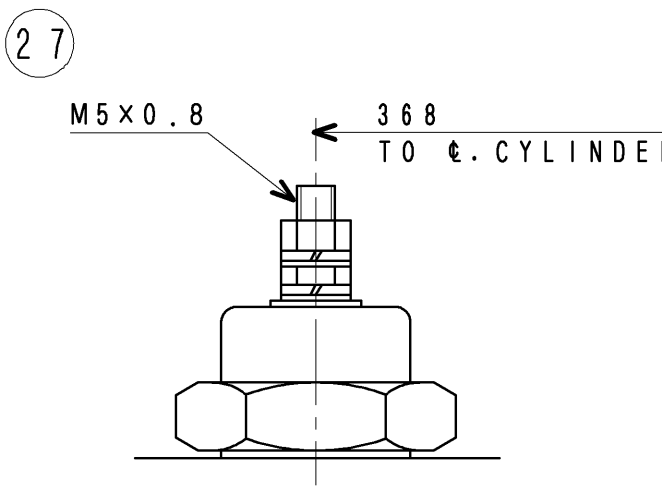

DETAIL OF FILTER ALARM

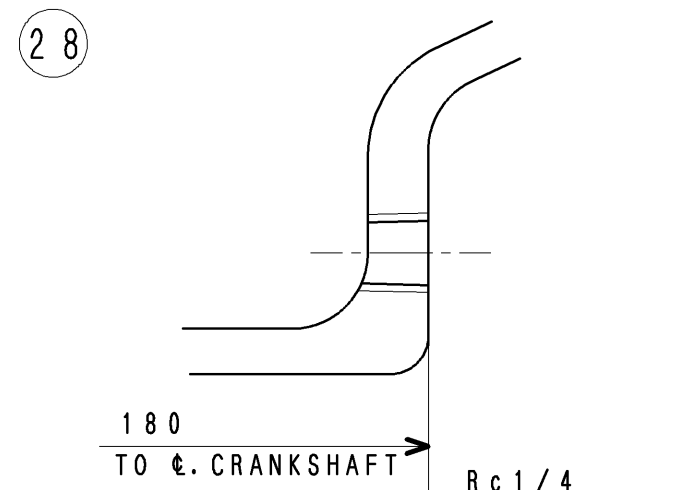

DETAIL OF AIR PRESS. GAUGE ADAPTER

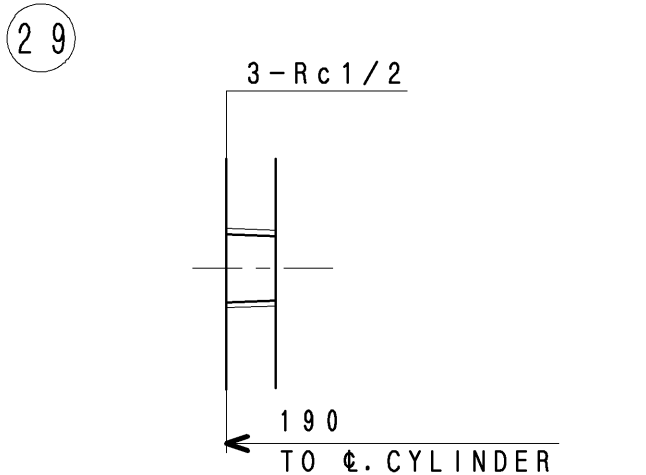

DETAIL OF THERMOMETER & THERMOSWITCH ADAPTER

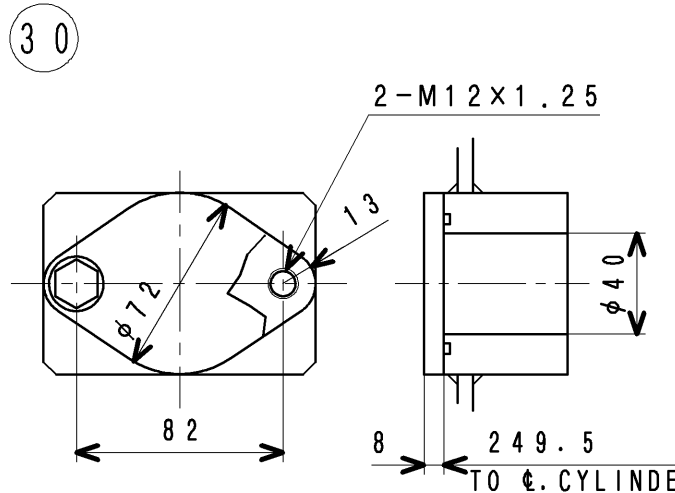

DETAIL OF OIL PAN ADAPTER (A)

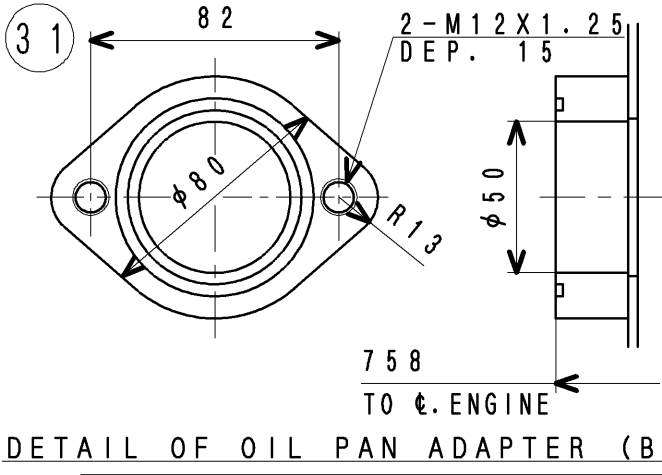

DETAIL OF OIL PAN ADAPTER (B)

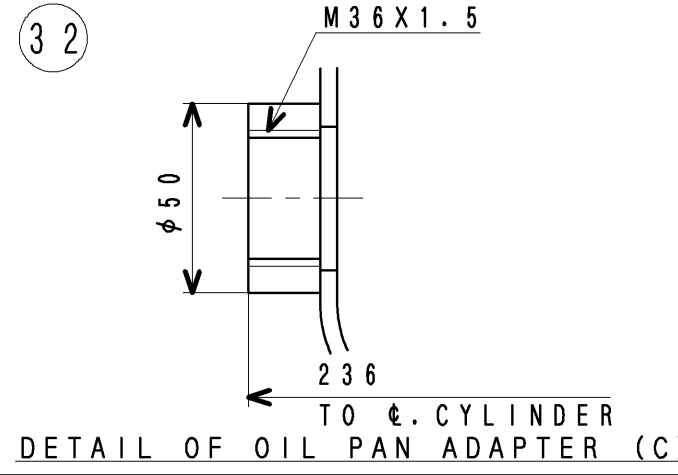

DETAIL OF OIL PAN ADAPTER (C)

MHI CONFIDENTIAL

MODEL
S6R-(T2)MPTK
S6R2-(T2)MPTK

CHG	ED-NO	DATE	CHK

3rd ANGLE PROJECTION  
尺度 SCALE

### S6R, S6R2 JOINT DETAIL

三菱重工業株式会社 汎用機・特車事業本部  
MITSUBISHI HEAVY INDUSTRIES, LTD. GENERAL MACHINERY & SPECIAL VEHICLES.

図面番号 45R96-01005  
DRAWING No.

③ 新図    サイズ A 3    ① 組立図    2 鋳鍛歯車品    3 板金溶接品    4 組立品  
4 旧引図    5 切削品    6 その他(購入品)

出図  
汎特  
2013  
7.5

M/C

33

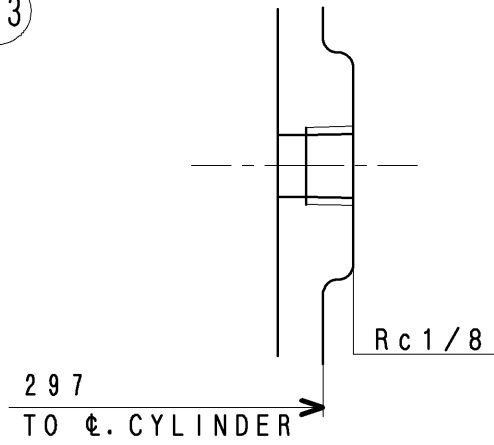

DETAIL OF OIL PRESS. GAUGE & PRESS. SWITCH ADAPTER

34

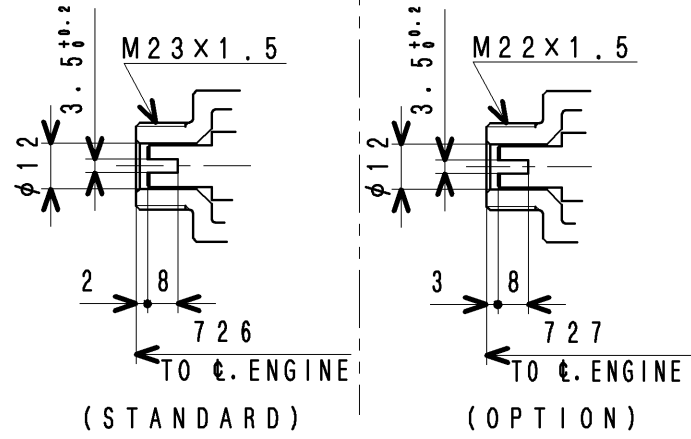

DETAIL OF TACHOMETER ADAPTER

35

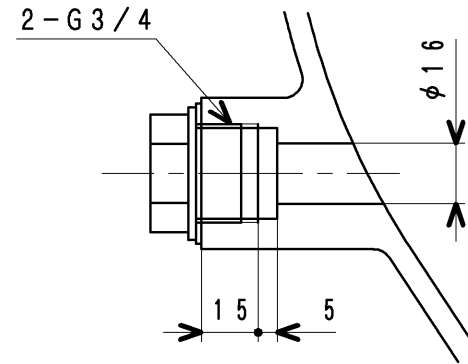

DETAIL OF THERMOMETER ADAPTER

36

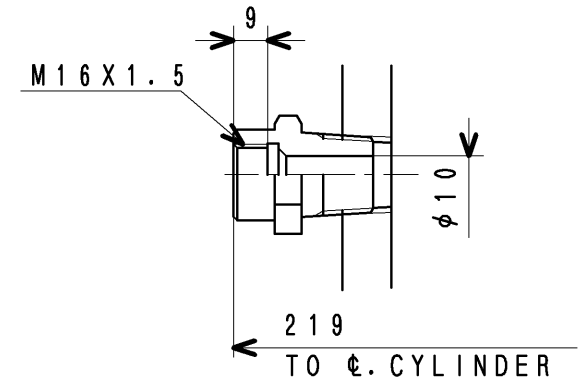

DETAIL OF THERMOMETER & THERMOSWITCH ADAPTER

MHI CONFIDENTIAL

CHG	ED-NO	DATE	CHK

3rd ANGLE  
PROJECTION  
尺度 SCALE

S6R, S6R2  
JOINT DETAIL

三菱重工業株式会社 汎用機・特車事業本部  
MITSUBISHI HEAVY INDUSTRIES, LTD. GENERAL MACHINERY & SPECIAL VEHICLES.

図面番号 45R96-01005  
DRAWING No. 2/2

③ 新図    サイズ    ① 組立図    2 鋳鍛歯車品    3 板金溶接品    4 組立品  
4 旧引図    A 3    5 切削品    6 その他(購入品)

出図  
汎特  
2013  
7.5

M/C



**MITSUBISHI DIESEL ENGINE  
TECHNICAL INFORMATION**

ITEM NO.

T0407-0015E Rev.2 (1/6)

DATE

Oct., 2011

**Performance Curves of S6R2-T2MPTK**

Performance Curves of S6R2-T2MPTK are enclosed herein. The data are test bench data and not a guaranteed performance.

THE INFORMATION HEREON IS THE PROPERTY OF MITSUBISHI HEAVY INDUSTRIES, LTD.  
WITHOUT WRITTEN PERMISSION, ANY COPYING, TRANSMITTAL TO OTHERS, AND ANY USE  
EXCEPT THAT FOR WHICH IT IS LOANED, IS PROHIBITED.

Revision	First Edition : Aug., 2011	Engine Engineering Department Engine System Designing Section		
	Rev.1 : Oct., 2011			
	Rev.2 : Mar., 2013	Approved by	Checked by	Drawn by

Rating: LIGHT DUTY-E3

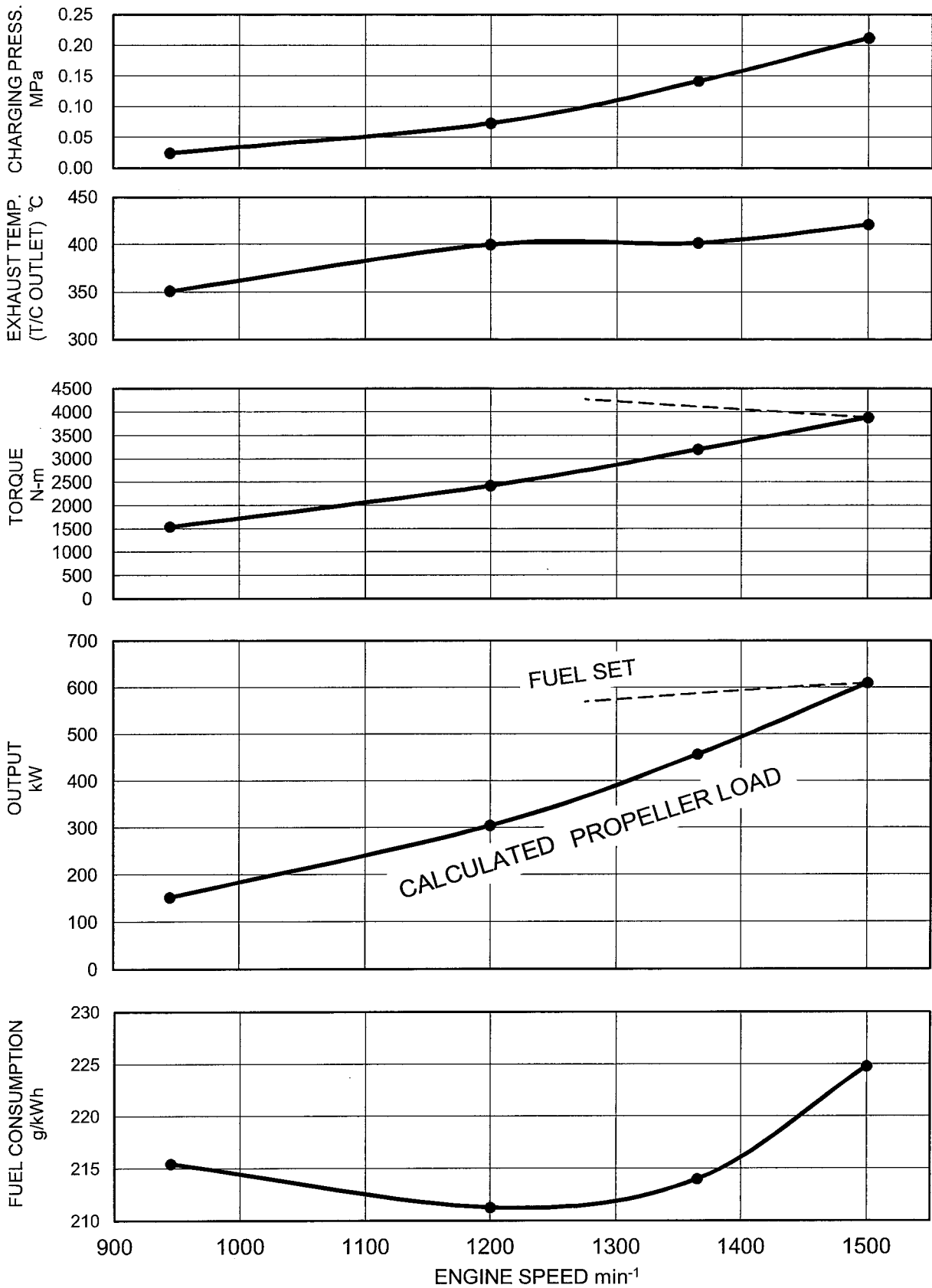

MHI CONFIDENTIAL

Fuel Consumption is based on ISO3046/1 with +5% tolerance at rated power.  
The specifications are subject to change without notice.

APPLICATION : MARINE PROPULSION

Pub. No.T0407-0015E Rev.2 2/6

Rating: MEDIUM DUTY-E3

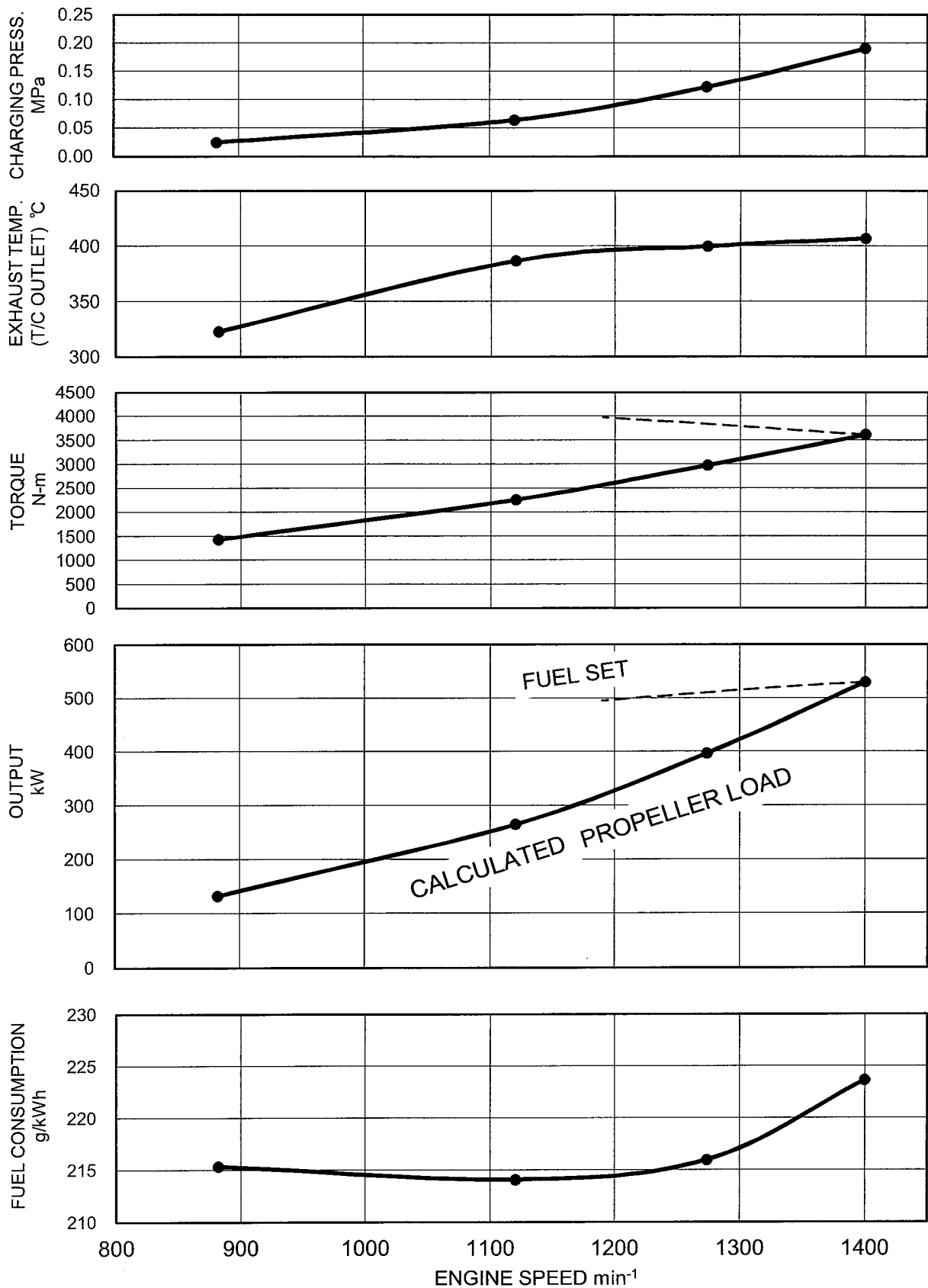

MHI CONFIDENTIAL

Fuel Consumption is based on ISO3046/1 with +5% tolerance at rated power.  
The specifications are subject to change without notice.

APPLICATION : MARINE PROPULSION

Pub. No.T0407-0015E Rev.2 3/6

Rating: HEAVY DUTY-E3

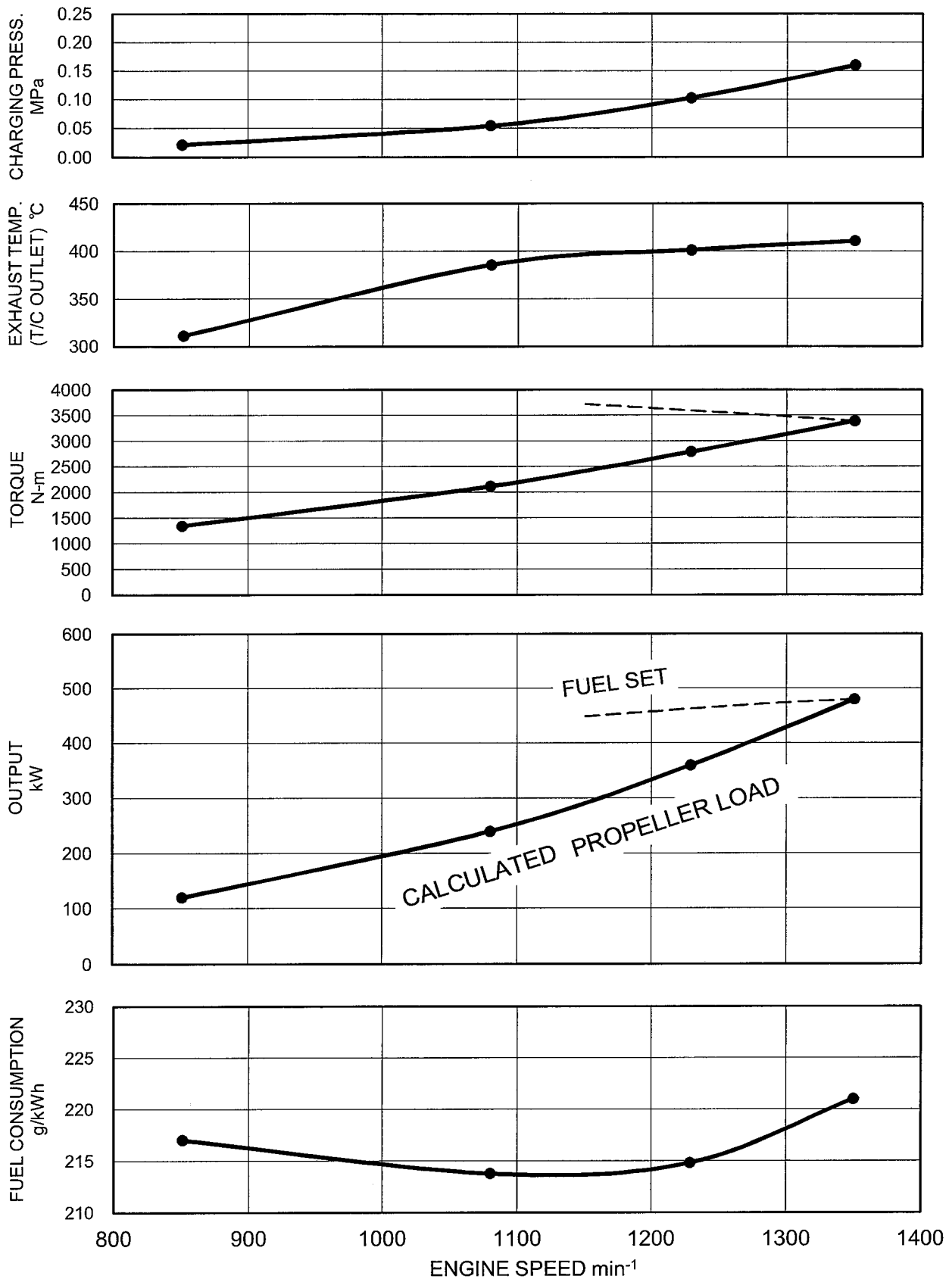

MHI CONFIDENTIAL

Fuel Consumption is based on ISO3046/1 with +5% tolerance at rated power.  
The specifications are subject to change without notice.

APPLICATION : MARINE PROPULSION

Pub. No.T0407-0015E Rev.2 4/6

Engine speed: 1200min<sup>-1</sup>

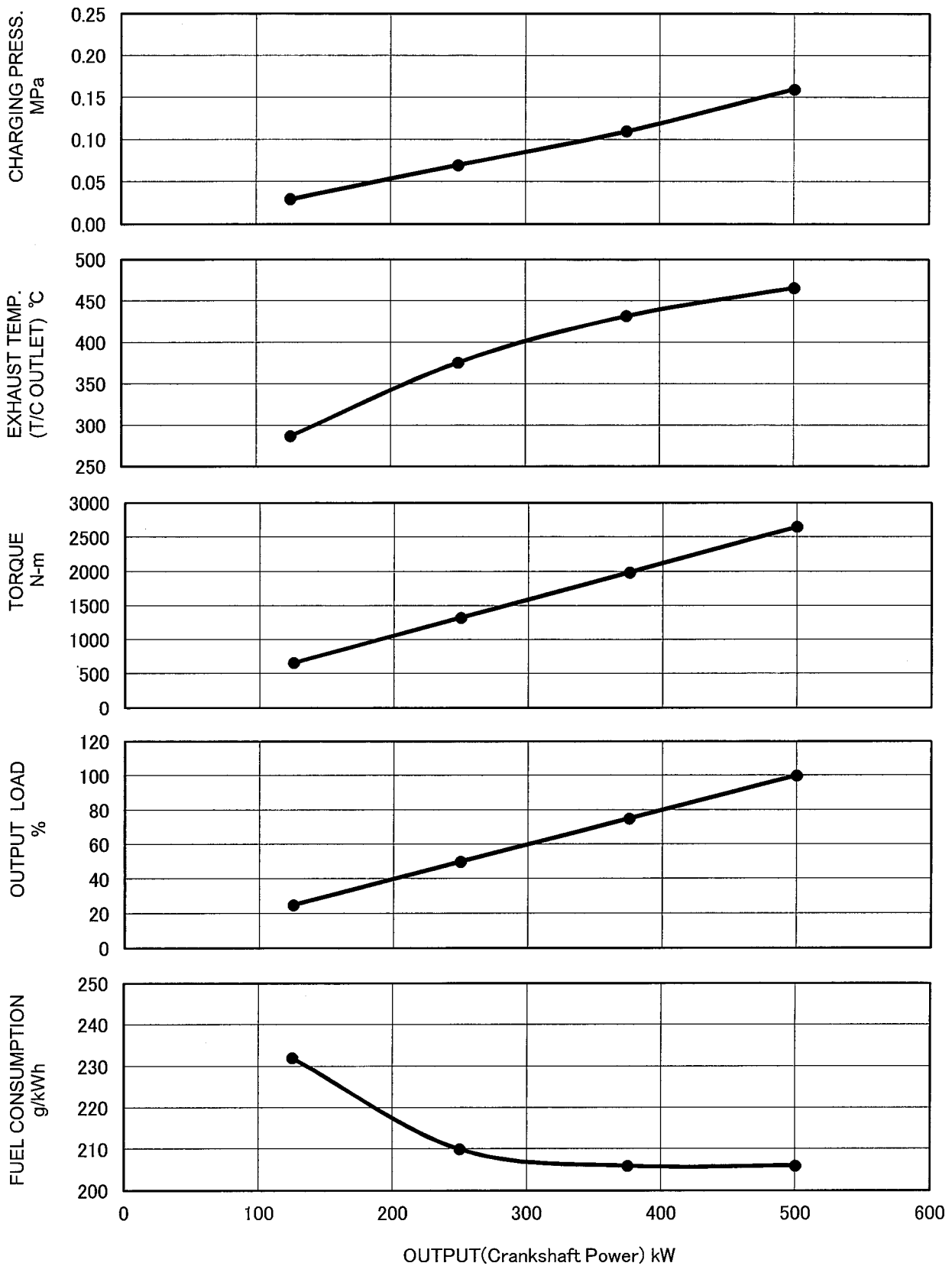

MHI CONFIDENTIAL

Fuel Consumption is based on ISO3046/1 with +5% tolerance at rated power.  
The specifications are subject to change without notice.

APPLICATION : GENERATOR

Pub. No.T0407-0015E Rev.2 5/6



Engine speed: 1500min<sup>-1</sup>

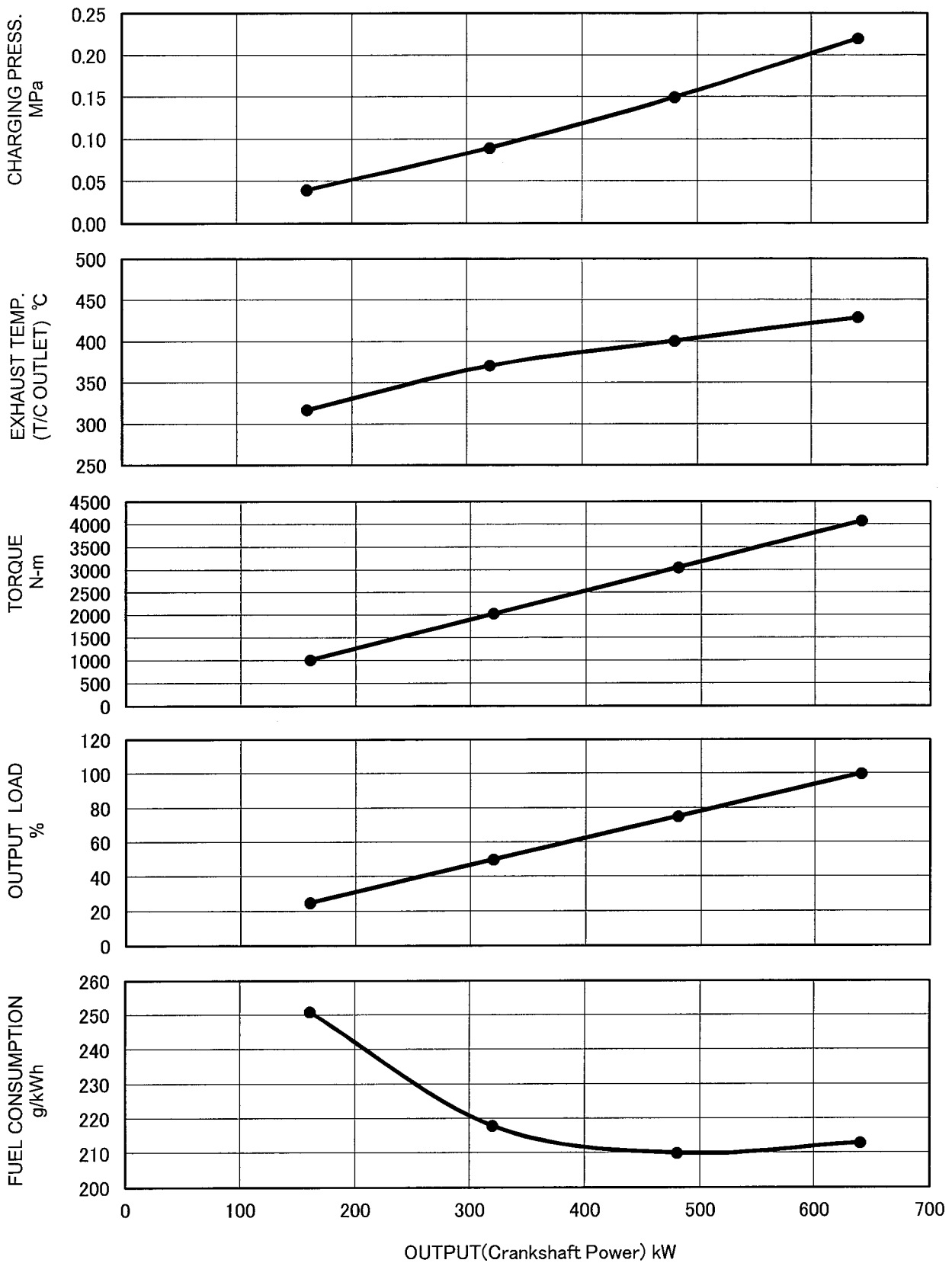

**MHI CONFIDENTIAL**

Consumption is based on ISO3046/1 with +5% tolerance at rated power.  
The specifications are subject to change without notice.

APPLICATION : GENERATOR

Pub. No.T0407-0015E Rev.2 6/6