



# **mitsubishi S12A2-(Z3)MPTAW**

Click on the headlines below to get redirected to the respective sections in this document.

[Technical data](#)  
[Elastic drawing](#)  
[Mounting details](#)  
[Connection details](#)



**MITSUBISHI DIESEL ENGINE  
TECHNICAL INFORMATION**

ITEM NO.

T0205-0009E (1/4)

DATE

August, 2009

Specification Sheets of S12A2-MPTAW Engine

Specification Sheets of S12A2-MPTAW Engine are enclosed herein.

Revision	First Edition : Aug., 2009	Engine Engineering Department Large Engine Design Section		
		Approved by	Checked by	Drawn by

## GENERAL ENGINE DATA

Type	-----	4-Cycle, Water Cooled	
Aspiration	-----	Turbo-Charged, Inter Cooler (Fresh water to Cooler)	
Cylinder Arrangement	-----	60°V	
No. of Cylinders	-----	12	
Bore mm(in.)	-----	150	(5.91)
Stroke mm(in.)	-----	160	(6.30)
Displacement Liter(in. <sup>3</sup> )	-----	33.93	(2071)
Compression Ratio	-----	15.3 : 1	
Dry Weight - Engine only - kg(lb)	-----	3380	(7453)
Wet Weight - Engine only - kg(lb)	-----	3606	(7951)

## PERFORMANCE DATA

Idling Speed -rpm	-----	600~650	
Maximum Overspeed Capacity - rpm	-----	2400	
Moment of Inertia of Rotating Components J- kg·m <sup>2</sup> (lb·ft <sup>2</sup> )	-----	10.65	(1011)
Cyclic Speed Variation with Flywheel at			
	1800rpm	-----	1/552
	1500rpm	-----	1/373

## ENGINE MOUNTING

Maximum Bending Moment at Rear Face of Flywheel Housing - N·m(lbf·ft)	-----	1961	(1447)
---	-------	------	--------

## AIR INLET SYSTEM

Maximum Intake Air Restriction (Includes piping)- kPa (in.H <sub>2</sub> O)	-----	3.92	(15.7)
Maximum Allowable Intake Air Temperature- °C (°F)	-----	45	(113)

## EXHAUST SYSTEM

Maximum Allowable Back Pressure - kPa (in.H <sub>2</sub> O)	-----	4.41	(17.7)
---	-------	------	--------

## LUBRICATION SYSTEM

Oil Pressure	at Idle - MPa (psi)	-----	0.2~0.3	(29~43)
	at Rate Speed - MPa (psi)	-----	0.5~0.6	(71~86)
Maximum Oil Temperature- °C (°F)	-----	110	(230)	
Oil Capacity of Marine Pan	High - liter (U.S.gal)	-----	120	(31.7)
	Low - liter (U.S.gal)	-----	92	(24.3)
Total System Capacity (Includes Oil Filter) - liter (U.S.gal)	-----	140	(37.0)	
Maximum Installation Angle	Front Up	-----	11°	
	Front Down	-----	9.5°	
Maximum Instantaneous Operating Angle	Front Up	-----	45°	
(Engine Level)	Front Down	-----	24°	
	Side to Side	-----	22.5°	

## COOLING SYSTEM

Coolant Capacity of Jacket(Engine only) - liter (U.S.gal)	-----	84	(22.2)	
Coolant Capacity of Air cooler(Engine only) - liter (U.S.gal)	-----	14	(3.7)	
Maximum External Friction Head at Engine Outlet-MPa(psi)	-----	0.034	(5.0)	
Recommended Static Head of Coolant above Crankshaft Center - m(ft)				
	MAX.	-----	10	(32.8)
	MIN.	-----	7	(23.0)
Standard Thermostat (Modulating)Range- °C (°F)	-----	71~85	(160~185)	
Maximum Coolant Temperature at Engine Outlet- °C (°F)	-----	95	(203)	
Recommended Coolant Temperature at Engine outlet- °C (°F)	-----	80	(176)	
Minimum Coolant Expansion Space-% of System Capacity	-----	10		
Maximum Coolant Temperature at Inter Cooler Inlet, PTAW type- °C (°F)	-----	38	(100)	

The specifications are subject to change without notice.

APPLICATION : MARINE

Pub. No. T0205-0009E 2/4

**FUEL SYSTEM**

Fuel Injection Pump	----- Bosch P Type x 2
Maximum Suction Head of Feed Pump - kPa (in. Hg)	----- 14.7 (4.3)
Maximum Level of Fuel Tank - m	----- 5.0
Continuous Use	----- 5.0
Stand-by Use	----- 2.0
Minimum Fuel Oil Supply Pipe Inner Diameter - mm(in.)	----- 20 (0.79)
Minimum Fuel Oil Leak Pipe Inner Diameter - mm(in.)	----- 20 (0.79)

**STARTING SYSTEM**

Battery Charging Alternator - V-Ah	----- 24-35
Starting Motor Capacity - V -kW	----- 24-7.5x2
Maximum Allowable Resistance of Cranking Circuit - m Ω	----- 1.5
Recommended Minimum Battery Capacity	
At 5°C (41°F) and above - Ah	----- 300
Below 5°C (41°F) through -5°C (23°F)	----- 500
Cranking Ampere of Starter at 5°C (41°F) / -5°C (23°F)	
Static Ampere -A	380 × 2 / 480 × 2
Momentary Ampere -A	680 × 2 / 900 × 2

**ACCESSORY EQUIPMENT**

Air Cleaner	Silencer Type
Exhaust Manifold	Air Cooled
Turbocharger	Air Cooled
Air Cooler	Fresh Water Cooled
Breather	Conduction Type
Governor	Hydraulic PSG Type
Fuel Injection Pump	
Fuel Feed Pump	
Fuel Injection Pipe	Double walled Type
Fuel Injection Nozzle	
Fuel Filter	Paper Element Type
Lubricating Oil Pump	
Lubricating Oil Cooler	
Lubricating Oil Filter(Full-Flow)	Paper Element Type
Lubricating Oil Filter(By-Pass Flow)	Paper Element Type
Oil Pan	Large Capacity,steel
Cooling Water Pump	
Cooling Water Thermostat	
Starter	Earth Float Type
Alternator	Earth Float Type
Stop Solenoid	DC24V-15A
Engine Support	Marine Type
Accessory Drive	Front Drive Pulley

**ACCESSORY EQUIPMENT(LOOSE SUPPLY)**

Relay Safety	For Starter
Jack Bolt	
Companion Flange	
Standard Tools	
Standard Spare Parts	

The specifications are subject to change without notice.

APPLICATION : MARINE

Pub. No. T0205-0009E

3/4

**ENGINE RATING**

All data represent net performance according to ISO3046 with standard accessories such as fuel injection pump, water pump L.O. pump and charging alternator under the condition of 100kPa(750 mm Hg), barometric pressure 298K(25°C) ambient temperature and 30% relative humidity.

B:Medium duty C:Heavy duty

ITEM Engine Model	UNIT	Propulsion use			Generator use		
		-MPTAW-2	-MPTAW-3	-MPTAW-4	-MPTAW-5		
		B	C	60Hz	50Hz		
Engine Speed	rpm	2000	1940	1800	1500		
No. of Cylinders		12					
Bore	mm (in.)	150 (5.91)					
Stroke	mm (in.)	160 (6.30)					
Displacement	liter (in. <sup>3</sup> )	33.93 (2071)					
Brake Horse Power	kW (HP)	776 (1040)	701 (940)	828 (1110)	709 (950)		
Brake Mean Effective Pressure	MPa (psi)	1.37 (199)	1.28 (186)	1.63 (236)	1.67 (242)		
Mean Piston Speed	m/s (ft/min)	10.7 (2106)	10.3 (2028)	9.6 (1890)	8.0 (1575)		
Maximum Regenerative Power Absorption Capacity	kW (HP)	116 (155)	109 (146)	93 (125)	68 (91)		
Intake Air Flow	m <sup>3</sup> /min (CFM)	72 (2542)	65 (2295)	77 (2719)	62 (2189)		
Exhaust Gas Flow	m <sup>3</sup> /min (CFM)	192 (6780)	173 (6109)	205 (7239)	163 (5756)		
Coolant Flow	liter/min (U.S. GPM)	1180 (312)	1160 (306)	1120 (296)	1000 (264)		
Coolant(Jacket water) Pressure (water pump outlet)	MPa (psi)	0.20 (28)	0.19 (27)	0.17 (24)	0.11 (16)		
Coolant Flow to Inter Cooler (Max. Flow: 600L/min)	liter/min (U.S. GPM)	400 (106)	400 (106)	400 (106)	400 (106)		
Oil Flow	liter/min (U.S. GPM)	410 (108)	400 (106)	370 (98)	310 (82)		
Radiated Heat to Ambient	kJ/hr (BTU/min)	228464 (3610)	206496 (3263)	243842 (3853)	194699 (3076)		
Heat Rejection to Coolant	kJ/hr (BTU/min)	1180398 (18650)	1066898 (16857)	1259848 (19906)	1005946 (15894)		
Heat Rejection to Inter Cooler	kJ/hr (BTU/min)	685393 (10829)	619489 (9788)	731525 (11558)	584098 (9229)		
Heat Rejection to Exhaust	kJ/hr (BTU/min)	2728774 (43115)	2466392 (38969)	2912441 (46016)	2154441 (34040)		
Noise Level (1 m height & distance) (excludes, Intake,Exhaust)	dB(A)	-	-	-	-		
Maximum No Load Governed Speed	rpm	2150	2086	1890	1575		

The specifications are subject to change without notice.

APPLICATION : MARINE

Pub. No. T0205-0009E 4/4



**MITSUBISHI DIESEL ENGINE  
TECHNICAL INFORMATION**

ITEM NO.

T0307-0025E (1/2)

DATE

April, 2007

Elastic data of S12A2-M Engine

Elastic data of S12A2-M Engine are enclosed herein.

Revision	First Edition : April, 2007 (Refer to MTD98-0224A, S12A2.0)	Engine Engineering Department Large Engine Design Section		
		Approved by	Checked by	Drawn by

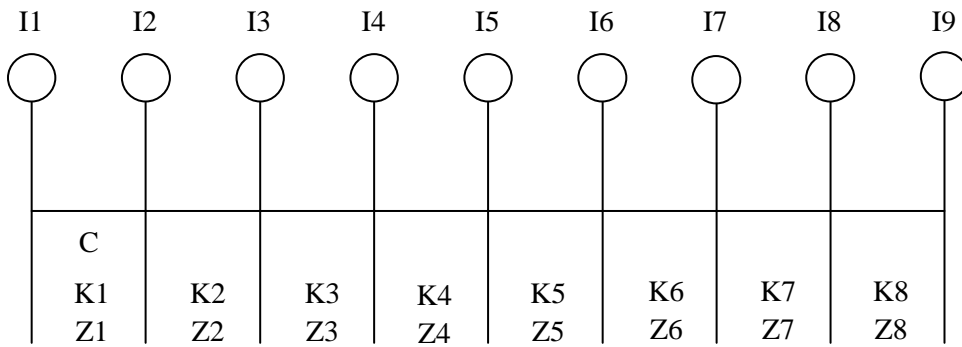

**S12A2-M ELASTIC DATA**

	Moment of inertia J kg.m <sup>2</sup>	Damping coefficient Nm/rad/s	Spring const. x10 <sup>7</sup> Nm/rad	Tensile strength N/mm <sup>2</sup>	Section modulus cm <sup>3</sup>
I1	DAMPER	1.11	C=587.4	K1=0	Z1 =0.0
I2	PULLEY	1.35	—	K2=0.655	Z2 =191.1
I3	No.1 CRANK	0.508	—	K3=0.406	Z3 =191.1
I4	No.2 CRANK	0.508	—	K4=0.406	Z4 =191.1
I5	No.3 CRANK	0.508	—	K5=0.406	Z5 =191.1
I6	No.4 CRANK	0.508	—	K6=0.406	Z6 =191.1
I7	No.5 CRANK	0.508	—	K7=0.406	Z7 =191.1
I8	No.6 CRANK	0.508	—	K8=0.664	Z8 =191.1
I9	FLYWHEEL	5.15	—		

Hysteresis constant:188 No. of Cylinder: 12 Bore:150mm Stroke:160mm

Length of Con-Rod: 290mm Mass of Reciprocating Parts: 8.586 kg

Firing order:1-12-5-8-3-10-6-7-2-11-4-9

Firing interval:0-60-120-180-240-300-360-420-480-540-600-660

APPLICATION : MARINE USE

The data is subject to change without notice.



**MITSUBISHI HEAVY INDUSTRIES, LTD.**  
GENERAL MACHINERY & SPECIAL VEHICLE

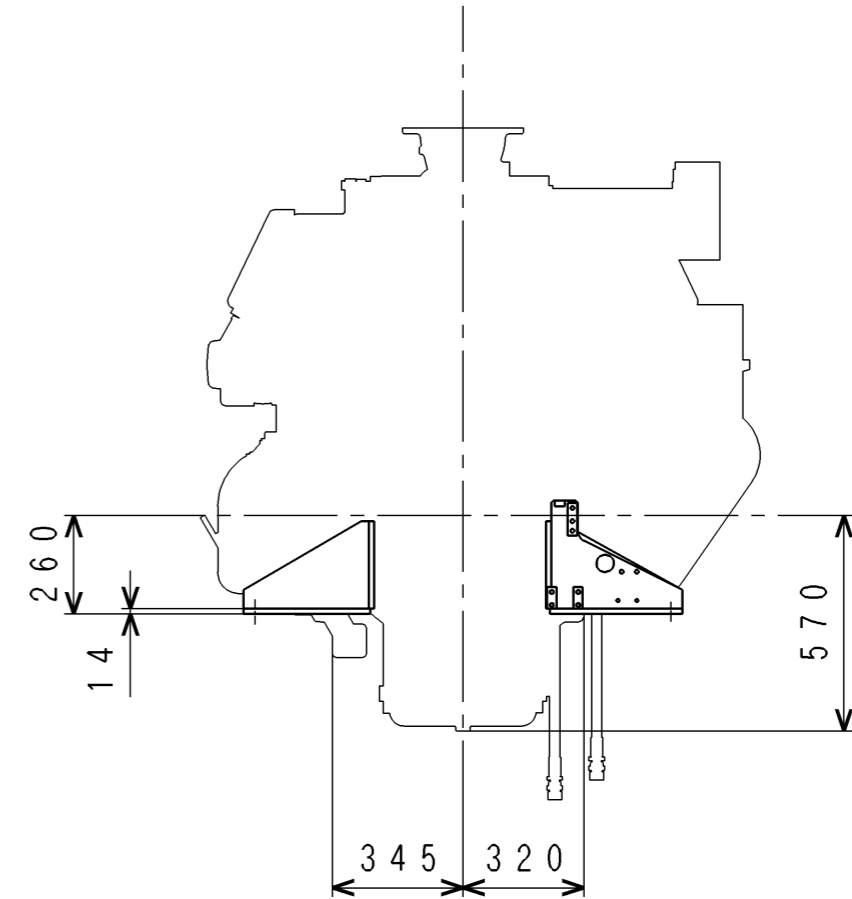
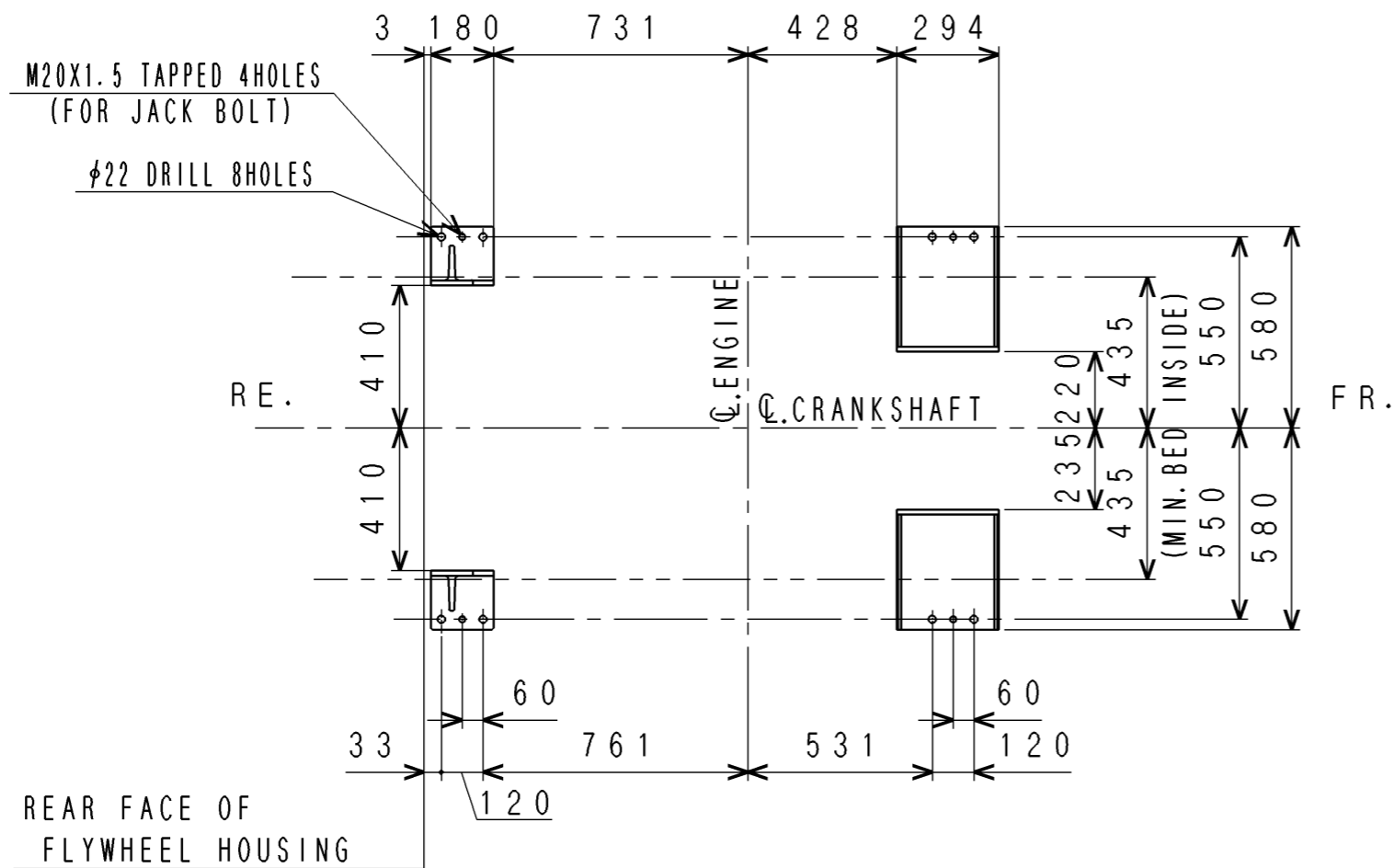

REAR FACE OF  
FLYWHEEL HOUSING

FR.

出図  
汎特  
2000  
10.30

FULL-CAD

CHG	EO-NO	DATE	CHK	 3rd ANGLE PROJECTION 尺度 SCALE :

# MOUNTING DETAIL S12A2

三菱重工業株式会社 汎用機・特車事業本部  
GENERAL MACHINERY & SPECIAL VEHICLE HEADQUARTERS, MITSUBISHI HEAVY INDUSTRIES, LTD.

図面番号  
DRAWING No. 45196-14003

- |       |     |       |         |            |       |
|-------|-----|-------|---------|------------|-------|
| ③ 新図  | サイズ | ① 組立図 | 2 鋳鍛歯車品 | 3 板金溶接品    | 4 組立品 |
| 4 旧引図 | A 3 |       | 5 切削品   | 6 その他(購入品) |       |



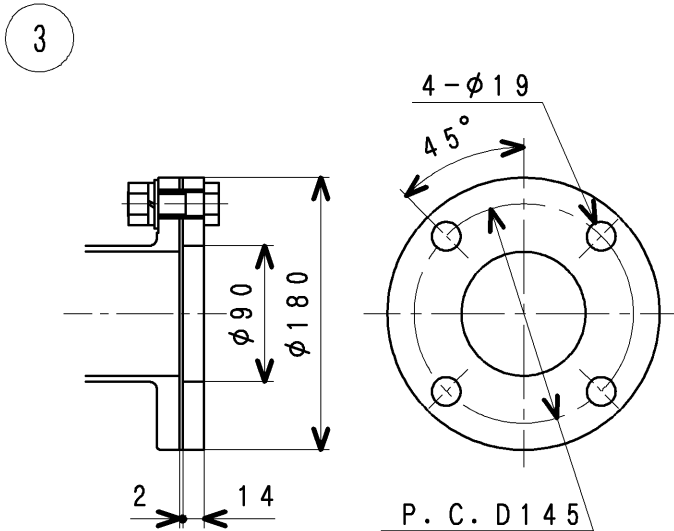

DETAIL OF FRESH WATER INLET

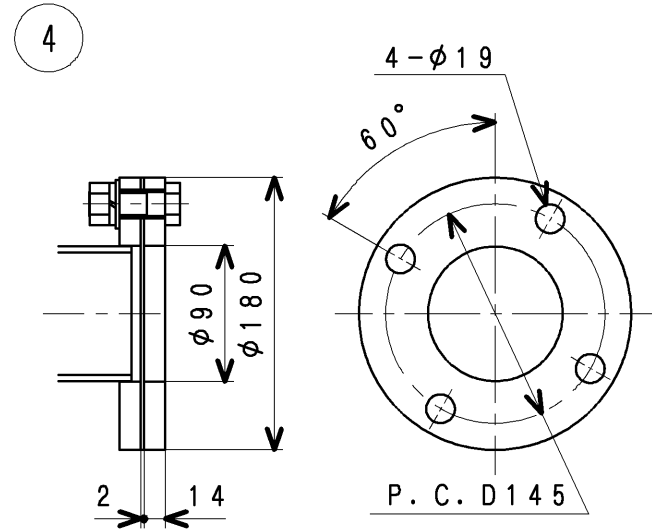

DETAIL OF FRESH WATER OUTLET

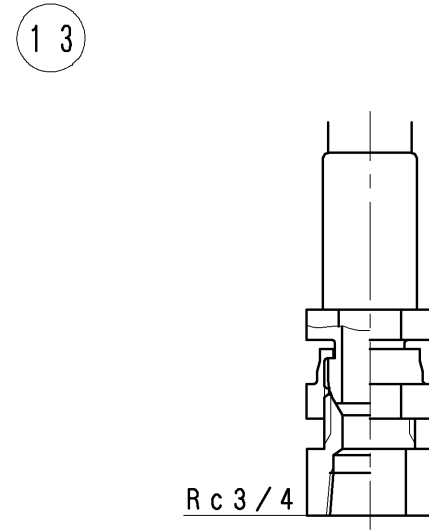

DETAIL OF FUEL PIPE ADAPTER

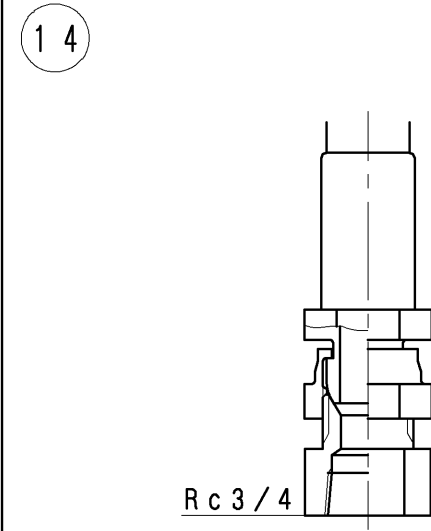

DETAIL OF FUEL LEAKOFF PIPE ADAPTER

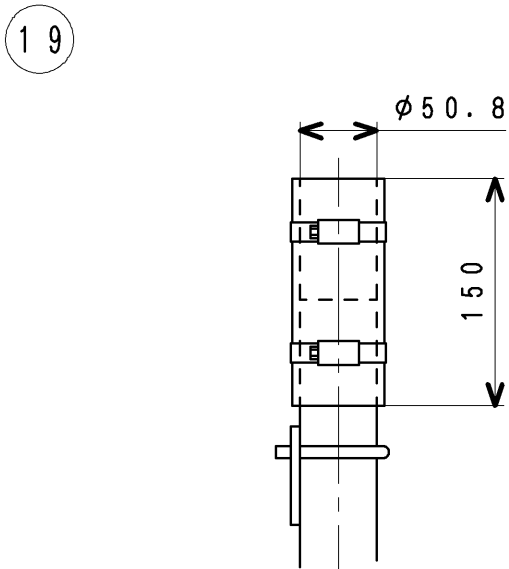

DETAIL OF MIST GAS OUTLET

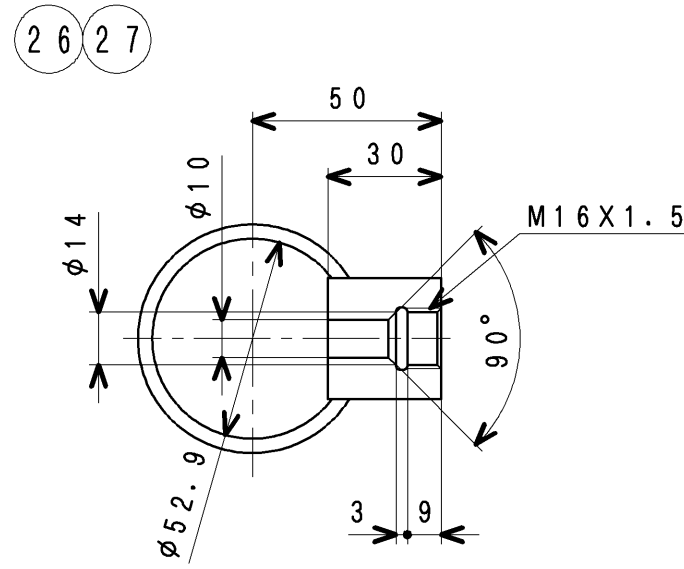

DETAIL OF THERMOMETER ADAPTER

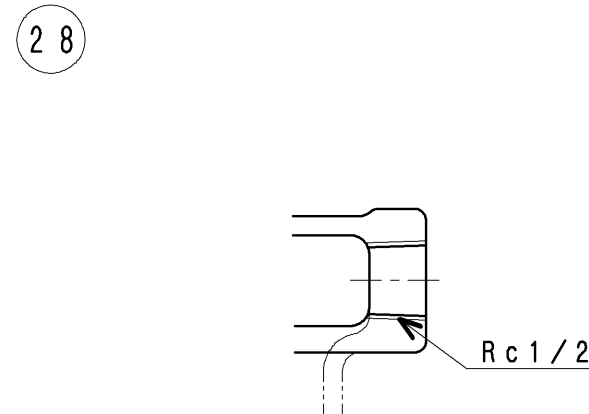

DETAIL OF THERMOSWITCHI ADAPTER

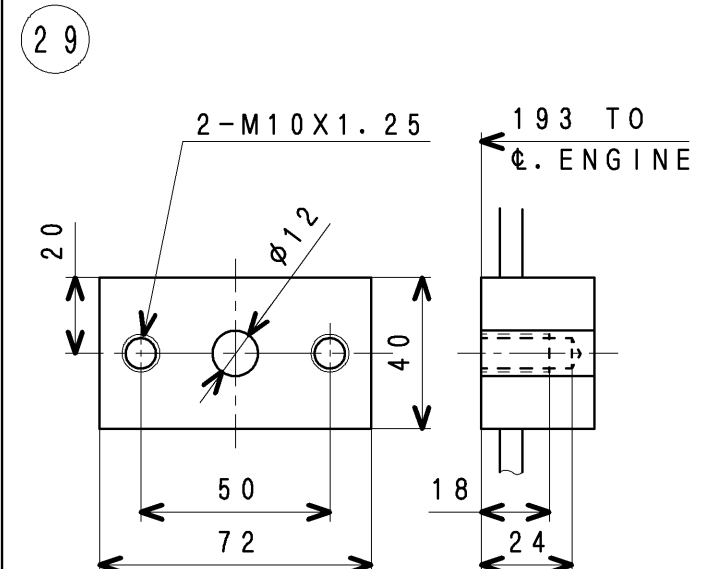

DETAIL OF OIL PAN ADAPTER

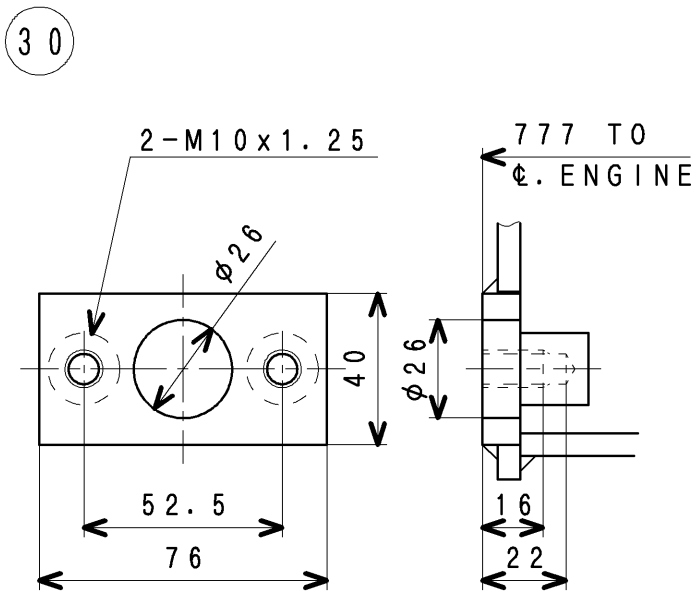

DETAIL OF OIL PAN ADAPTER

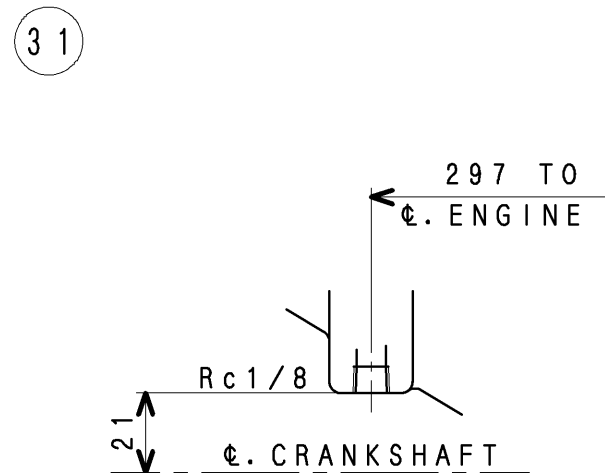

DETAIL OF OIL PRESS. GAGE & PRESS. SWITCHI ADAPTER

MHI CONFIDENTIAL

MODEL
S12A2-C2MPTK
S12A2-(Z3)MPTAW
S12A2-Y2MPTK

S12A2  
JOINT DETAIL  
三菱重工業株式会社 汎用機・特車事業本部  
MITSUBISHI HEAVY INDUSTRIES, LTD. GENERAL MACHINERY & SPECIAL VEHICLES.  
図面番号 45196-01010  
DRAWING No. 45196-01010

旧引  
汎特  
2013  
7.5

M/C

32

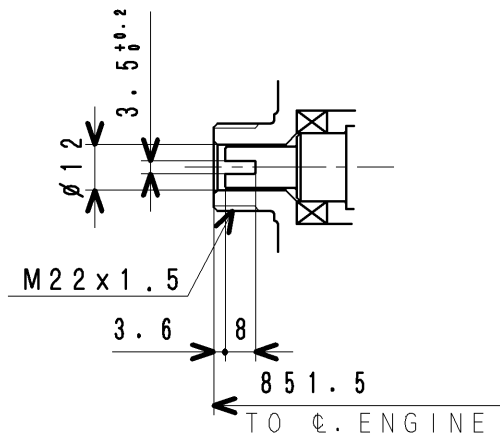

DETAIL OF TACHOMETER JOINT

33

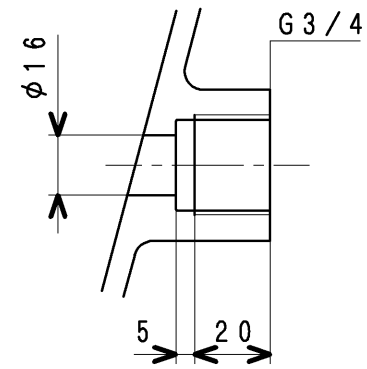

DETAIL OF THERMOMETER ADAPTER  
(EXHAUST GAS)

34 35

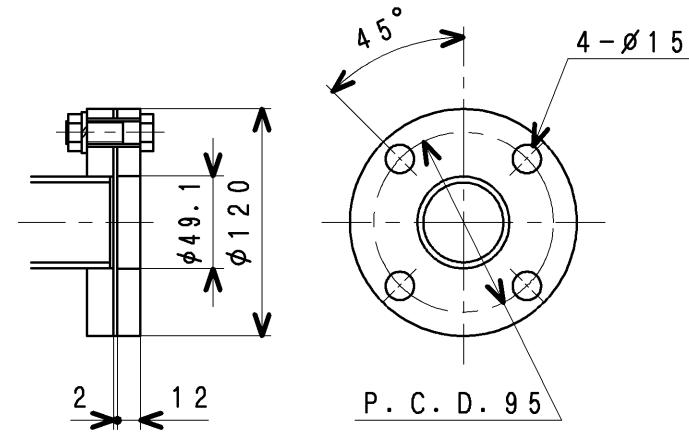

AIR COOLER WATER INLET  
AIR COOLER WATER OUTLET

旧引  
▲  
汎特  
2010  
8.31

FULL-CAD

# S12A2 JOINT DETAIL

三菱重工業株式会社 汎用機・特車事業本部  
GENERAL MACHINERY & SPECIAL VEHICLE HEADQUARTERS, MITSUBISHI HEAVY INDUSTRIES, LTD.

図面番号 45196-01010 2  
DRAWING No. 2/2

3 新図	サイズ A 3	① 組立図	2 鋳鍛歯車品	3 板金溶接品	4 組立品
④ 旧引図			5 切削品	6 その他(購入品)	